

Instruction Manual

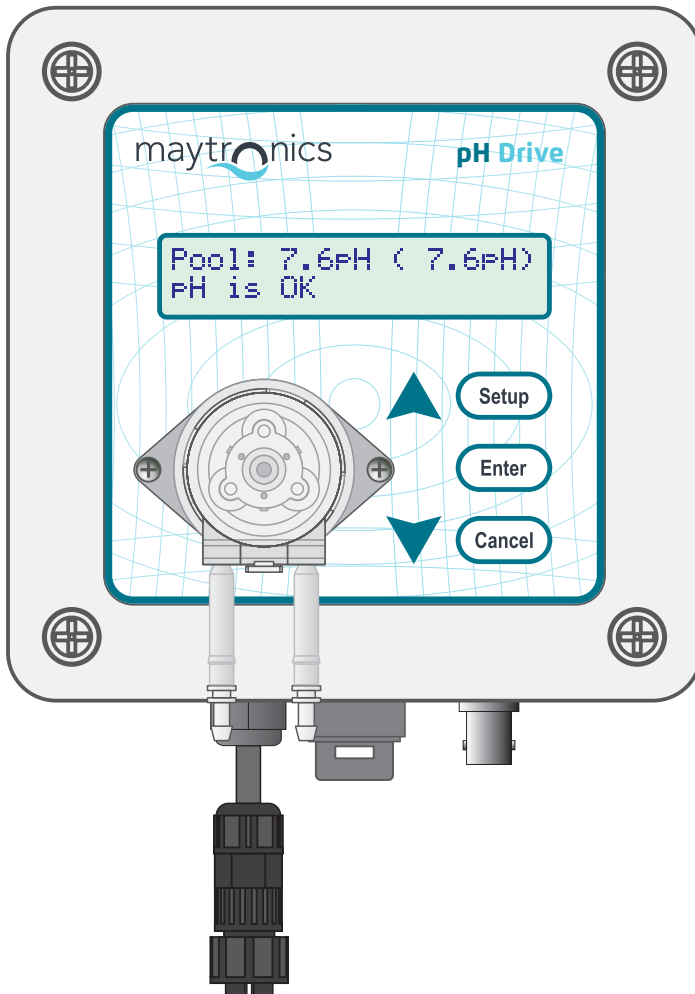



Thank you for purchasing the Maytronics pH Drive.

The **pH Drive** has been designed for maximum reliability and long service life. Please be sure to follow the instructions in this manual to get the best performance and life from your equipment.

The **pH Drive** is quite easy to operate, and this manual will explain each of the steps clearly. Troubleshooting and hints are also included to allow you to get the most from your unit. If you require assistance at any stage, please contact your Maytronics Authorised Dealer.

	Page
CAUTIONS & WARNINGS.....	3
GETTING TO KNOW YOUR pH DRIVE.....	4
pH DRIVE DISPLAY.....	5
ACID SAFETY & DILUTION.....	6
pH TEE INSTALLATION.....	7
pH DRIVE INSTALLATION.....	8
TUBE INSTALLATION.....	9
pH SENSOR INSTALLATION.....	10
CONNECT POWER LEAD.....	10
pH DRIVE SETTINGS.....	11
Setting the Mode.....	11
Adding a Quick Dose of Chemical.....	11
Setting the pH Set Point.....	12
Pool Size Setting.....	12
Enabling or Disabling the pH Alert Function.....	13
When the pH Alert is Triggered.....	13
pH SENSOR CALIBRATION.....	14
Inline Calibration.....	14
pH7.0 Buffer Calibration.....	15
CHANGING PUMP CASSETTE.....	16
TROUBLESHOOTING.....	17
WARRANTY.....	19
CONTACT US.....	19



Cautions & Warnings

- Please read the instructions fully and keep this manual on hand whenever operating or maintaining your **pH Drive**.
- **Always use diluted acid. Concentrated acid will cause damage to the squeeze tube and fittings, which are not covered by the warranty.**
See page 6 for information on the safe handling and dilution of acid.
- DO NOT add acid into a drum that previously contained liquid chlorine until that drum has been rinsed three times with fresh water. Ensure that the label on the drum indicates that the drum contains acid.
- As for all pool equipment and chemicals, the **pH Drive** should be installed out of reach of children. Children must not have access to operating the **pH Drive** without adult supervision.
- Although the **pH Drive** has a weather resistant design, its service life will be considerably longer if it is not exposed to direct sunlight and rain. Wear and tear from direct exposure to the elements is not covered by the warranty.
- Do not allow grass or weeds to grow around the **pH Drive**, or the tubing and cables to prevent accidental damage from garden trimming equipment.
- Any damaged cables must be replaced immediately to prevent electrical shock.
- Unplug the **pH Drive** power lead before servicing or changing the dosing pump cassette.
- The **pH Drive** must be serviced only by an authorised service agent. Please contact your Maytronics Authorised Dealer for details. Despite being low-voltage powered, opening the unit may still cause an electric shock, which can cause injury or death.



Getting to know your pH Drive

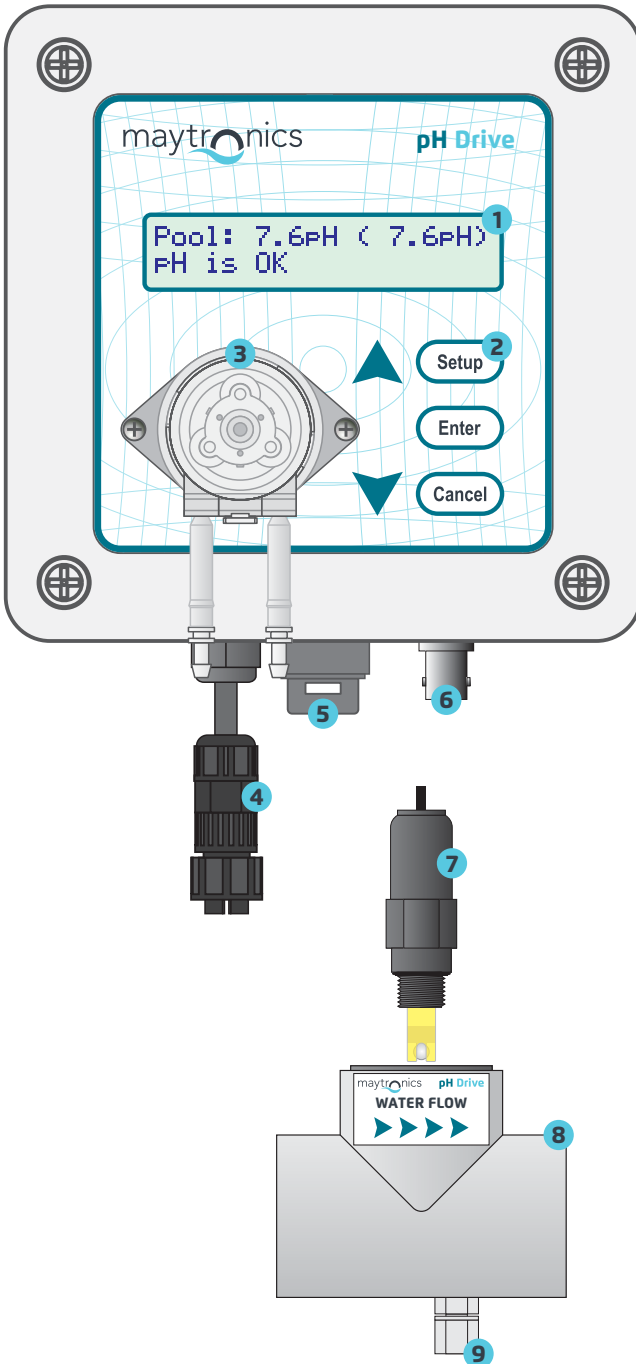

1 DISPLAY

User-friendly plain text menu and help system.

2 KEYPAD

Used for setup and maintenance of your **pH Drive**.

3 DOSING PUMP

High quality, low maintenance peristaltic dosing pump.

4 POWER CONNECTOR

IP65 Waterproof connector plugs into Maytronics Ozone Swim systems that are equipped with the matching outlet.

5 MOUNTING CLIP

Pull the clip downwards when mounting the **pH Drive** to the mounting rail, or to unclip when removing.

6 pH SENSOR SOCKET

Connect the pH Sensor to the BNC pH Sensor socket.

7 pH SENSOR

Commercial quality pH Sensor screws into pH Tee to firm hand tightness.

8 pH TEE

A single pH Tee for installing the pH Sensor and non-return injection valve.

9 NON-RETURN VALVE

High quality polypropylene non-return injection valve.

Q pH Drive Display



1 POOL pH

This is the readout of the current pH of your pool.

2 SET POINT

The **pH Drive** maintains the pool pH at the programmed Set Point.

3 INFORMATION LINE

This is where **pH Drive** indicates helpful messages and warnings, so you know what's happening at all times.

pH is OK.....The current pH of the pool is within the Set Point. No dosing is required at this time.

Adding Acid (or Base)The **pH Drive** is operating the dosing pump to add acid or base to correct the pH of the pool back to the Set Point. The default setup of the **pH Drive** is to add acid.

pH Alert! Reset:EnterThe pH of the pool has been above the Set Point for 4 hours or more, without returning to the Set Point. Press Enter to reset the alert timer.

24 Hr Delay.....The user has selected the 24 Hour Delay function. This is normally used when buffer or other chemicals have been added to the pool, which can temporarily change pool pH. The 24 Hour Delay function prevents excessive usage of acid or base.

Acid (or Base) Pump is Off....The user has set the dosing pump to being totally off, regardless of the pool pH reading.

Mixing Time Delay.....After the dosing pump has added a quantity of acid or base, the **pH Drive** will switch it off for some time. This allows the added acid or base to mix through the pool before adding more, if required.

Cool Squeeze TubeThe dosing pump has stopped for a short time to allow the squeeze tube to cool down.

Startup Time Delay.....The **pH Drive** has just been switched on, and is waiting for its pH reading to become stable, before doing any automatic control.

pH is Out of Range.....The **pH Drive** has detected that the pool pH reading is extreme and needs to be checked.

pH Calibration Due.....12 months has passed since the last time that the **pH Drive** was calibrated. Calibration ensures that pool pH readings are accurate.

Change Pump CassetteThe dosing pump has operated for 50 hours or more, which is time for the pump cassette to be replaced. This is important maintenance.



Acid Safety & Dilution

Maytronics recommends using pre-diluted acid purchased from your reputable pool shop or service agent.

Alternatively, this section provides information on the safe handling and dilution of acid to use with your pH Drive. Please take the time to read and understand this section, to prevent injury or illness due to acid spillage.

Safety Information

- Dilute acid in a well ventilated area, preferably outdoors.
- Have a supply of fresh running water (e.g. a garden hose) readily to hand, in case of spillage.
- Wear protective clothing, safety goggles and gloves when diluting acid.
- Use only a Dangerous Goods certified drum. Your pool store can advise on this.
- If an acid spillage does occur, wash down well with copious amounts of fresh water immediately. **Seek Medical advice if any acid burn has occurred or if breathing is affected.**

Acid Dilution Procedure

1. DO NOT add acid into a drum that previously contained liquid chlorine, until that drum has been thoroughly rinsed three times with fresh water.
2. Fill a 20 or 25 Litre dangerous goods certified drum to around half way with fresh water.
3. Add 5 Litres of concentrated Hydrochloric, Muriatic or Non-Fuming acid to the drum. Pour slowly to prevent spillage.
4. Top up the drum with more fresh water. Do not overfill.
5. Replace the drum lid and swish around to mix the acid well with the water. Keep this drum lid fitted until the diluted acid drum is in position.

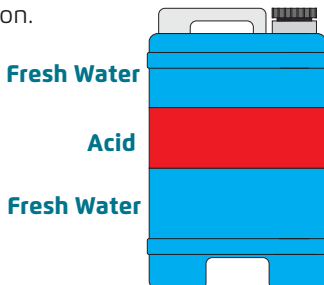

Additional Information

- Always use acid to at least 3 parts water to 1 part acid. Damage from undiluted or insufficiently diluted acid is not covered by the warranty.
- Always add acid to water. Never add water to acid.
- The acid drum must be below the level of the non-return valve in the pH Tee when installed. This prevents acid syphoning into the pipeline.
- Fit the Acid Drum label supplied with your **pH Drive** to your drum of diluted acid. This will identify its contents and shows the dilution instructions.

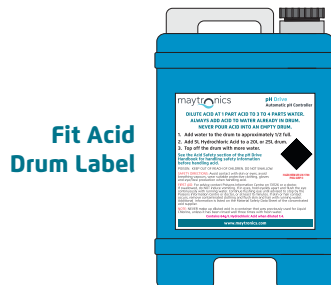

Install the pH Tee first, so that the glue can set while you are installing the pH Drive unit itself.

Pre-Installation Checklist

- You will require a saw suitable for cutting PVC pipe, PVC Primer and PVC Glue.
- Install the pH Tee after the filter, before any sanitation equipment, but after heating equipment.
- The pH Tee must be fitted to a horizontal section of pipe, so that the pH Sensor is within 45° of vertical (with the glass bulb pointing downwards).
- The pH Tee should be installed before an Ozone venturi, Salt Chlorinator cell, Electro Oxidizing Cell or Liquid Chlorine injection point.
- For installations into 40mm Pipe, a pair of 50x40 mm reduction bushes have been supplied. Glue these into the pH Tee before installing the Tee.
- Check the Water Flow direction arrows on the pH Tee label, and ensure that it is installed in the correct direction.

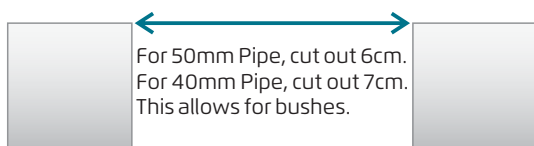

CUT PIPE

The pH Tee must be fitted to the return to pool pipe, where the water is clean and the pressure is low.

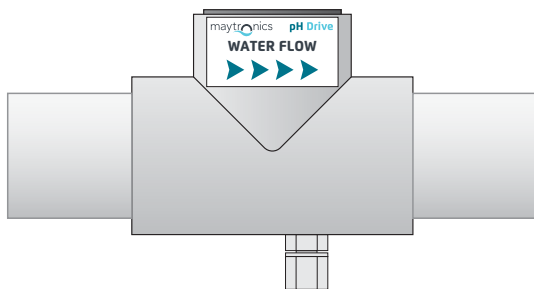

GLUE IN pH TEE

- Use PVC primer on all surfaces to be glued.
- Use suitable PVC pressure glue for joints.
- Ensure Water Flow arrows are pointing in the correct direction.
- pH Sensor must be within 45° of vertical.

These examples are all correct:

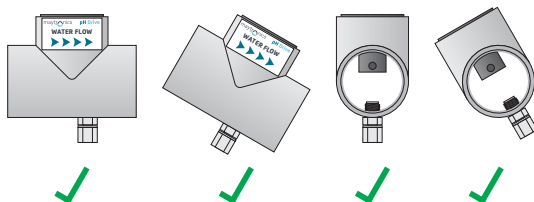

These are incorrect:

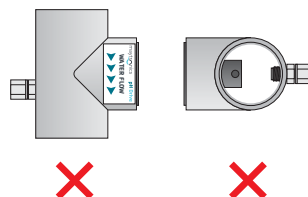

Pre-Installation Checklist

- The **pH Drive** unit **MUST** be mounted vertically, with the cables at the bottom, in order to be weather resistant. Any water ingress due to the unit being incorrectly mounted is not covered by warranty.
- Check the mounting bracket of the Ozone Swim system with which your **pH Drive** is being installed. If it has an extension for mounting the **pH Drive**, then you do not need to install the mounting rail supplied with the **pH Drive**.
- Choose a position that will allow the cable from the **pH Sensor** to reach the **pH Drive** without straining, and power lead to reach the outlet on the Ozone Swim system. The dosing pump tubes must also be able to reach the chemical drum and the pH Tee.
- Ensure that the **pH Drive** is protected from direct sunlight and weather. Although the unit has a weather resistant design, damage from long term exposure is not covered by the warranty.
- Do not connect the **pH Drive** power lead to the Ozone Swim outlet until all installation steps are complete.

INSTALL MOUNTING PLATE

Install the mounting plate level in the desired location. Screws and wall plugs are provided. This step is not required if your Ozone Swim system has an extended bracket for mounting the **pH Drive**.

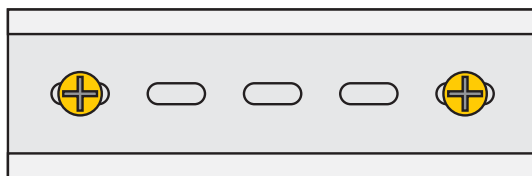

MOUNT pH DRIVE

- 1 Hook the **pH Drive** mounting clip onto the top rail of the mounting plate.
- 2 Pull the mounting clip down pull pushing the **pH Drive** against the bottom rail of the mounting plate.
- 3 Allow the mounting clip to lock in place behind the bottom rail.

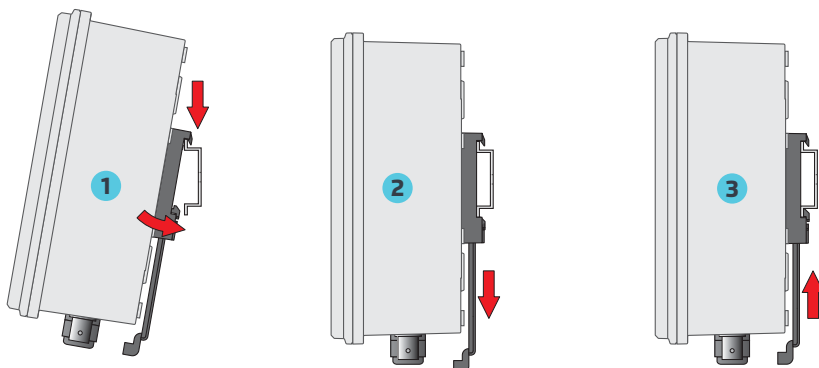



Tube Installation

pH TEE TUBE INSTALLATION

- 1 Remove the nut from the non return valve on the Tee piece. Slip the Nut over the tube.
- 2 Push the tube firmly onto the tube fitting.
- 3 Tighten the nut over the tube. Tighten firmly with fingers. If the tubing can still be easily pulled out, use a tool to tighten an extra 1/2 turn to ensure that it is securely fastened.

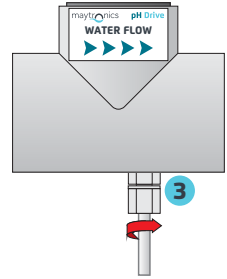
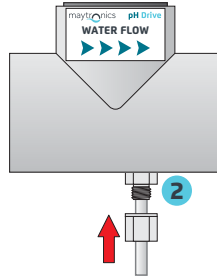
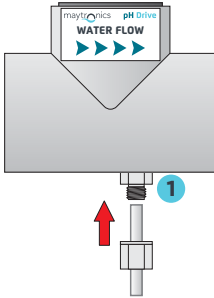

DRUM WEIGHT TUBE INSTALLATION

1. Remove the lid from the acid drum that you will use.
2. Drill a 7.0mm hole into the drum lid.
3. Push the end of the drum weight tube through the drum lid.
4. Fit the tube onto the drum weight tube fitting in the same way as described in the pH Tee Tube Installation section above and illustration below.

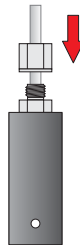
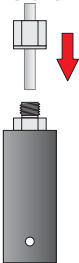

DOSING PUMP TUBE INSTALLATION

Suction tube on left side

Delivery tube on right side

Suction tube fed through 7.0mm hole, drilled into acid drum lid.

Acid safety label fitted to drum.

Drum weight inside acid drum.

Delivery tube firmly fixed into non return valve in pH Tee.

- Cut Suction and Supply tubes to required length from the single length of clear PVC tube supplied with the **pH Drive**.
- Push Suction and Supply tubes onto dosing pump fittings, and fasten in place with black cable ties supplied.



pH Sensor Installation

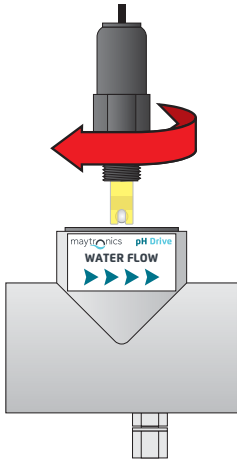

1. Carefully remove the protective cap from the tip of the sensor.
2. Screw the pH Sensor into the pH Tee thread. Tighten firmly by hand. **DO NOT OVERTIGHTEN. DO NOT USE A TOOL.**
3. After the pH Sensor is installed in the pH Tee, connect plug on the pH Sensor cable into the sensor socket on the **pH Drive**. Push the plug into place and 1/4 turn clockwise to lock it into place.



Connect Power Lead

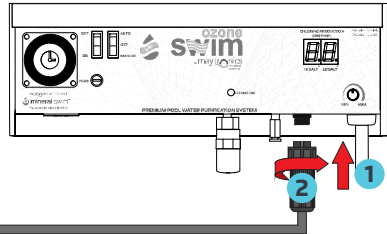
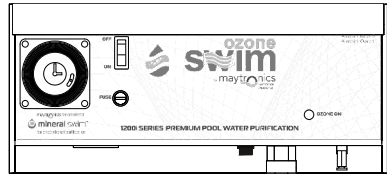
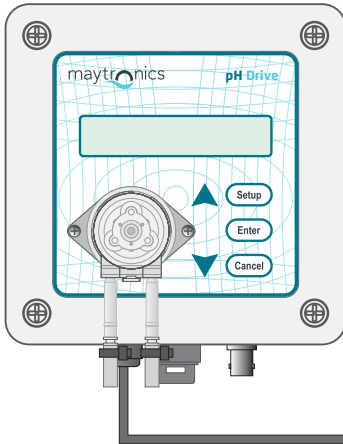

1. Locate the **pH Drive** power socket on your Maytronics Ozone Swim system. Remove the dust cover. The keyway of the power socket is towards the front of the unit. Align the **pH Drive** plug with the keyway of the socket and push in.
2. Screw the retaining nut of the plug clockwise until finger tight to lock the plug into place with a weather tight seal.

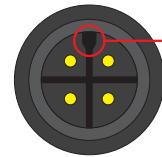

Keyway

All installation steps are now complete. It is recommended that you now use the Quick Dose function with 1 Litre of fresh water to test the system for leaks before using your pH Drive with acid.



pH Drive Settings

- Press **Setup** to enter the user-friendly menu system.
- Press **▲** and **▼** to scroll through menu choices, then press **Enter** to select the required option.
- Press **Enter** to save changes.
- Press **Cancel** to quit without saving changes at any screen.
- All setup screens time out if no key has been pressed for 30 seconds. Any changes will not be saved.

Setting the Mode

- Press **Setup** to enter the user-friendly menu system, then press **▲** and **▼** until **Mode** is selected. The current mode is shown in brackets.

Setup

```
Mode (Auto Control)
Scroll:▲▼ Set:Enter
```

- Press **Enter** to go to the **Mode** menu.

Enter

```
Mode: Auto Control
Set:▲▼ Save:Enter
```

- Press **▲** and **▼** to select between the Mode settings:

Auto Control ... The dosing pump will add acid or base when the pH is outside the Set Point.

Standby The dosing pump is switched off and will not add any acid or base automatically.

24Hr Delay.... The dosing pump is switched off for 24 hours, to allow buffer or other chemical to mix and stabilise.

▲ ▼

```
Mode: Standby
Set:▲▼ Save:Enter
```

▲ ▼

```
Mode: 24Hr Delay
Set:▲▼ Save:Enter
```

- Press **Enter** to save the selection, or press **Cancel** to quit without saving.

Adding a Quick Dose of Chemical

- Use this function if you need to manually add a dose of acid or base to the pool
- Press **Setup** to enter the user-friendly menu system, then press **▲** and **▼** until **Quick Dose** is selected.
- Press **Enter** to go to the **Quick Dose** menu.
- Press **▲** and **▼** to select the number of litres of acid or base to dose into the pool. The range of settings is 1 to 5 litres.
- Press **Enter** to start dosing, or press **Cancel** to quit.
- The **pH Drive** counts down the litres as it doses.
- Every 4 minutes of dosing pump operation, the **pH Drive** will switch it off for 1 minute, to allow the squeeze tube to cool down. This extends squeeze tube life.

Setup

```
Quick Dose
Scroll:▲▼ Set:Enter
```

Enter

```
Quick Dose: 0L
Set:▲▼ Save:Enter
```

▲ ▼

```
Adding Acid
4.9 of 5 Litres
```

```
Cooling Squeeze Tube
4.2 of 5 Litres
```



pH Drive Settings

Setting the pH Set Point

The default pH Set Point of 7.6 is suitable for most pool systems. You should only change this setting if advised by a pool professional.

- Press **Setup** to enter the user-friendly menu system, then press **▲** and **▼** until **pH Set Point** is selected. The current Set Point is shown in brackets.
- Press **Enter** to go to the **pH Set Point** menu.
- Press **▲** and **▼** to set the required pH Set Point.
- Press **Enter** to save the new setting, or press **Cancel** to quit without saving.

Setup

```
pH Set Point (7.6pH)
Scroll:▲▼ Set:Enter
```

Enter

```
pH Set Point: 7.6pH
Set:▲▼ Save:Enter
```

Pool Size Setting

The pH correction demand and pool turnover time is different from pool to pool, even when two pools are the same size. The Pool Size setting will be suitable for the majority of pools. However, it may be necessary to adjust this during the first few days or weeks of operation, as detailed in this section.

- Press **Setup** to enter the user-friendly menu system, then press **▲** and **▼** until **Pool Size** is selected. The current Pool Size setting is shown in brackets.
- Press **Enter** to go to the **Pool Size** menu.
- Press **▲** and **▼** to set the required Pool Size.
- Press **Enter** to save the new setting, or press **Cancel** to quit without saving.

Setup

```
Pool Size (40,000L)
Scroll:▲▼ Set:Enter
```

Enter

```
Pool Size: 40,000L
Set:▲▼ Save:Enter
```

NOTES

If the **pH Drive** does not keep up with acid or base demand, and the Alarm sounds, increase the Pool Size setting by one step and check in 2 days.

If the **pH Drive** overdoses too much acid or base, reduce the Pool Size setting by one step and check in 2 days.

New concrete pools have an extremely high acid demand for the first few months. It may be necessary to enter a Pool Size up to 50% more than the true size of the pool if your **pH Drive** is not keeping up with acid demand during this initial period. The setting can be reduced again 1 to 3 months later.



pH Drive Settings

Enabling or Disabling the pH Alert Function

The **pH Drive** will sound an alarm and display an alert if the pH has been outside the set point for 4 hours or more.

If this function is disabled, the alarm will never be triggered and the **pH Drive** may over dose acid or base. Only advanced users should change this setting, and only as a temporary measure.

- Press **Setup** to enter the user-friendly menu system, then press **▲** and **▼** until **pH Alerts** is selected. The current Set Point is shown in brackets.
- Press **Enter** to go to the **pH Alerts** menu.
- Press **▲** and **▼** to select between On and Off.
- Press **Enter** to save the selection, or press **Cancel** to quit without saving.

When the pH Alert is Triggered

When the pH Alert is triggered, the **pH Drive** will display the alert message and sound the beeper.

```
Pool: 7.6pH ( 7.6pH)
pH Alert!Reset:Enter
```

- The Dosing Pump will now be disabled, and will not operate again until the Alert has been reset.
- Press **Enter** to reset the pH Alert.
- Refer to the list of possible causes and fixes on this page, to rectify the condition that caused the alert to be triggered.

```
Setup
pH Alerts (On)
Scroll:▲▼ Set:Enter
```

```
Enter
pH Alerts: On
Set:▲▼ Save:Enter
```



```
pH Alerts: Off
Set:▲▼ Save:Enter
```

Possible causes and solutions for the pH Alert being triggered:

CauseVery high acid demand in new concrete pool.

FixIncrease Pool Size Setting to a higher value until the acid demand settles to normal amounts.

CauseAcid or Base drum empty.

FixRefill drum with water and acid or base as per instructions on page 6.

CausePool Size Setting is too low or too high.

FixSee page 12 for information on how to change Pool Size Setting.

CausepH Reading is inaccurate.

FixRe-calibrate pH Sensor.

CausepH Sensor broken or faulty.

FixIf re-calibration is not possible, then replace pH Sensor.

CausePump is not pumping acid correctly.

FixCheck all tube fittings for leakage. Re-fit or replace as necessary.

Check squeeze tube inside pump cassette for leakage and replace if necessary.



pH Sensor Calibration

The **pH Drive** will display a reminder to calibrate the pH Sensor approximately every 12 months:

```
pH Calibration Due
```

The pH Sensor should be calibrated to ensure that the readout is correct. Calibration is simply the process of placing the pH Sensor into a solution of known pH, and adjusting the readout to that value.

The **pH Drive** can be calibrated in one of two ways:

1. Inline Calibration

This is done by obtaining an accurate pH measurement of the pool water and adjusting the readout to that value.

2. pH7.0 Buffer Calibration

This involves removing the pH Sensor from the pH Tee, placing it into a pH7.0 Buffer solution, and adjusting the readout to 7.0.

Inline Calibration

1. Measure the pH of the Pool

Set the **pH Drive** to Standby or 24Hr Delay mode an hour or more before measuring the pH of the pool. Do not change back to Auto Control mode until after pH calibration is completed.

Ensure that the pool filtration pump has been running and no acid has been added for at least 1 hour prior to doing an Inline Calibration. This is to ensure that the pH level is stable throughout the whole pool.

Measure the pH of the pool with a good quality, calibrated pH meter. Alternatively, take a sample of pool water to a pool shop which has an electronic pool balance measurement system. A standard pool pH test kit is NOT accurate enough to be relied upon for pH calibration.

2. Calibration Procedure

- Press **Setup** to enter the user-friendly menu system, then press **▲** and **▼** until **Calibrate pH Sensor** is selected.
- Press **Enter** to go to the **Calibration** screen.

```
Cal: 7.6pHx ( 7.7pH)
Set:▲▼          Cal:Enter
```

The current reading is displayed in brackets. The flashing "X" indicates that the reading is not yet stable. DO NOT calibrate until the "X" changes to a "✓"

```
Cal: 7.6pH✓ ( 7.7pH)
Set:▲▼          Cal:Enter
```

- Press **▲** and **▼** to set the "Cal:" pH value to the pH of the pool, as measured in step 1.
- Press **Enter** to calibrate the pH Sensor, or press **Cancel** to quit without calibrating.
- Set the **pH Drive** back to Auto Control mode.

Calibration Failure

If pH calibration fails, the **pH Drive** will display this message:

```
pH Calibration Fail
Check Handbook
```

- Clean the pH Sensor as per the troubleshooting section, then retry calibration.
- If the calibration failure persists, the pH Sensor will most likely need to be replaced.

pH7.0 Buffer Calibration is on the next page.



pH Sensor Calibration

pH7.0 Buffer Calibration

The **pH Drive** is powered from your Ozone Swim unit. The **pH Drive** will need power for calibration, but with the pH Sensor removed from the pH Tee, the pool pump must not be running. You will therefore need to unplug the pool pump from the Ozone Swim unit.

1. Prepare pH7.0 Calibration Buffer

- A sachet containing 2 ziplock bags of salt was supplied with your **pH Drive**. Simply pour BOTH sachets into the 250mL bottle and fill to the 250mL mark with deionised or distilled water. Shake well until all salts have dissolved.
- This solution will last up to 6 months after it has been made, providing it is not contaminated and is stored in a cool, dark place

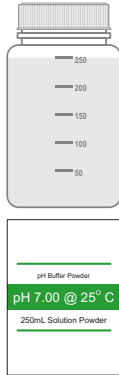

2. Remove the pH Sensor from the Tee

- Disconnect the pH Sensor to avoid straining the cable and plug when removing the sensor from the pH Tee. Unscrew the sensor completely from the Tee.
- Reconnect the pH Sensor to the **pH Drive**.
- Rinse the sensor well in clean water. De-ionized or distilled water is ideal, but tap water will suffice.

3. Place pH Sensor into pH7.0 Buffer

- Decant a small amount of pH7.0 buffer into a clean cup. Place the pH Sensor into this buffer, so it is immersed to 15mm or more, as per the diagram on the right.
- DO NOT place the pH Sensor directly into the 250mL bottle of pH7.0 buffer.

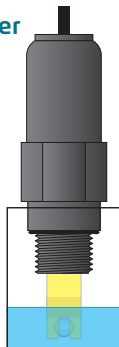

4. Calibration Procedure

- Switch the **pH Drive** on by activating the pool pump output of the Ozone Swim unit.
- Press **Setup** to enter the user-friendly menu system, then press **▲** and **▼** until **Calibrate pH Sensor** is selected.
- Press **Enter** to go to the **Calibration** screen.

```
Cal: 7.0pHx ( 7.1pH)
Set:▲▼ Cal:Enter
```

The current reading is displayed in brackets. The flashing "X" indicates that the reading is not yet stable. DO NOT calibrate until the "X" changes to a "✓"

```
Cal: 7.0pH✓ ( 7.0pH)
Set:▲▼ Cal:Enter
```

- Press **▲** and **▼** to set the "Cal:" pH value to exactly **7.0**.
- Press **Enter** to calibrate the pH Sensor, or press **Cancel** to quit without calibrating.

5. Re-fit pH Sensor and Power Connections

- Disconnect the pH Sensor from the **pH Drive** to avoid straining the cable and plug when screwing into the pH Tee. Re-fit into the pH Tee. Re-connect the pH Sensor to the **pH Drive** when done.
- Re-connect the pool pump to the Ozone Swim power outlet.
- Switch your pool equipment back on.

Calibration Failure

If pH calibration fails, the **pH Drive** will display this message:

```
pH Calibration Fail
Check Handbook
```

- Clean the pH Sensor as per the troubleshooting section, then retry calibration.
- If the calibration failure persists, the pH Sensor will most likely need to be replaced.



Changing Pump Cassette

The **pH Drive** monitors the running time of the dosing pump and will display a reminder to replace the pump cassette when this time exceeds 50 hours.

Change Pump Cassette

- The **pH Drive**'s dosing pump squeeze tube is contained in a complete replaceable cassette, so replacing the squeeze tube is a simple matter of replacing the cassette.
- Use the Quick Dose function to pump 1 Litre of fresh water through the system. This will ensure that all acid or base has been flushed out and will make it safe to handle.
- Switch off the **pH Drive** and ensure that the pool pump is also off.
- Remove the clear PVC Suction and Supply tubes. Either cut the cable ties and pull the tubes off, or trim back the tubes by 20mm or more.
- Turn the pump cassette anti-clockwise around 1/8 of a turn. When you feel it stop, pull the cassette off the base.

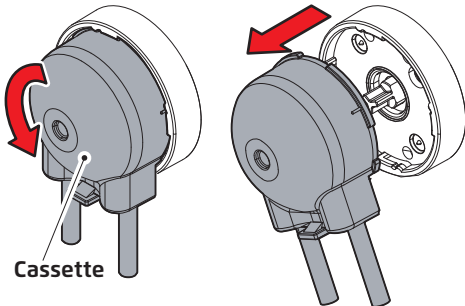

- Push the replacement dosing pump cassette onto the pump base. Rotate it a few degrees either way to make the axle in the pump base align with the hole in the back of the cassette. Once it has engaged, push the cassette onto the base at the angle shown at the top, right of this page.

- Turn the cassette clockwise around 1/8 of a turn until it clicks into place.

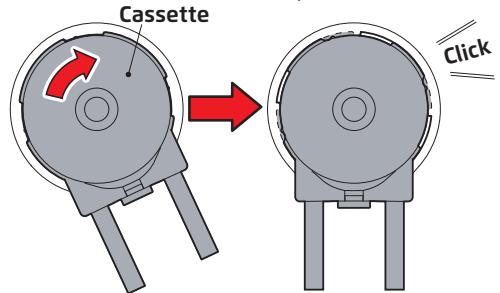

- Refit the clear PVC Suction and Supply tubes. Suction is on the left and Supply is on the right. Fasten in place with new black UV resistant cable ties.

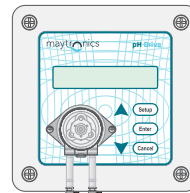

Suction tube on left side (From Drum) Supply tube on left side (To pH Tee)

- Switch the **pH Drive** back on.

Resetting the Pump Cassette Reminder

- Press **Setup** to enter the user-friendly menu system, then press **▲** and **▼** until **Maintenance** is selected.
- Press **Enter**, then select **Cassette** from the **Maintenance** menu. The total pump operating hours is displayed on the right.

```
Cassette (50.00Hr)
Scroll:▲▼ Set:Enter
```

- At the **Change Pump Cassette** screen, press **Enter** to reset the Pump Cassette hours to zero. Press **Cancel** to exit if the pump cassette was not replaced.

```
Change Pump Cassette
No:Cancel Yes:Enter
```

❓ Troubleshooting

Symptom	Possible Causes and Remedies
Unstable or inaccurate pH readings	pH Sensor is dirty. <ul style="list-style-type: none"> • Disconnect pH Sensor from the pH Drive, then unscrew sensor from the pipe. • Wipe the glass bulb with a soft tissue soaked with methylated spirits. • Soak the tip of the sensor in diluted Hydrochloric acid (for example, from your pH Drive diluted acid drum). • Rinse the pH Sensor thoroughly in clean water. • Screw sensor back into pipe and re-connect sensor to pH Drive.
	pH Sensor needs to be re-calibrated. <ul style="list-style-type: none"> • Clean pH Sensor as per procedure above. • Re-calibrate pH Sensor as per details on pages 14 and 15.
	Pool water is very pure and has low conductivity. <ul style="list-style-type: none"> • Add one bag of pool salt per 50,000 Litres of pool water.
pH reading cannot be calibrated	pH Sensor is dirty. <ul style="list-style-type: none"> • Follow the pH Sensor cleaning procedure above.
	pH Sensor is faulty. <ul style="list-style-type: none"> • Replace pH Sensor.
pH reads around pH7 without changing	Short circuit in pH Sensor BNC Plug or Socket <ul style="list-style-type: none"> • Disconnect pH Sensor plug from socket. Dry out with a hair dryer or allow to air dry. Reconnect and re-check. • If problem persists, return pH Sensor to have connector replaced, or replace the pH Sensor.
pH reads around pH4 to 5 without changing	Glass bulb or internal stem of pH Sensor is cracked. <ul style="list-style-type: none"> • Replace pH Sensor.
Unit does not power up	Faulty Unit <ul style="list-style-type: none"> • Faulty pH Drive main unit. Return for repair.
Unit is not adding acid when dosing pump is operating	<ul style="list-style-type: none"> • Check that the pH Drive diluted acid drum is not empty. • Check that all suction and output tubes are fitted correctly, with no leakage. • Check that squeeze tube inside pump cassette is not leaking. <p>WARNING : IF ANY ACID HAS LEAKED OUT OF TUBES, WASH DOWN THE AREA WITH FRESH WATER IMMEDIATELY. TAKE THE LID OFF THE PUMP, REMOVE SQUEEZE TUBE AND WASH OUT WITH FRESH WATER IF SQUEEZE TUBE WAS LEAKING.</p>
Alarm sounds due to pH being too low	Pool Size Setting is set too high <ul style="list-style-type: none"> • Reduce the Pool Size Setting by one level and check in 2 days.
Acid Pump turns, but acid is not flowing.	Leaking or worn squeeze tube and/or rollers. <ul style="list-style-type: none"> • Tighten Acid Pump fittings further or replace fittings. • Replace dosing pump cassette as needed (see page 16).

IF YOU NEED TO RETURN YOUR **pH DRIVE** FOR SERVICE OR REPAIRS AT ANY TIME, PLEASE USE THE QUICK DOSE FUNCTION (PAGE 11) TO DOSE 1 LITRE OF FRESH WATER THROUGH THE SYSTEM BEFORE SENDING BACK. THIS WILL STOP ACID LEAKING FROM THE PUMP DURING TRANSPORT (WHICH WOULD DAMAGE YOUR UNIT OR THE PACKAGING, VOIDING WARRANTY), AND IS ALSO A SAFETY HAZARD FOR OUR TECHNICIANS.

❓ Troubleshooting

Alert Messages	Possible Causes and Remedies
Pool: 7.6pH (< 7.6pH) pH Alert!Reset:Enter	<p>pH has been outside of Set Point for more than 4 hours of operation.</p> <ul style="list-style-type: none"> Please refer to page 13 for a complete list of possible causes and remedies when the pH Alert message is flashing. The pH Drive will not attempt any further acid addition until the alarm is cleared. Press Enter to clear the alarm after rectifying the issue.
Pool:13.0pH (< 7.6pH) pH is Out of Range	<p>pH reading is above pH12 or below pH2.</p> <ul style="list-style-type: none"> This alert is displayed immediately if the pH reading goes outside the range of pH2 to pH12. A beeper also sounds. This alert can only be cleared when the pH returns to normal range. Check the actual pH of the pool with an independent test. Attempt to calibrate the pH Drive (see pages 14 and 15). If calibration fails and the issue persists, the pH sensor may require replacement.
Reminder Messages	Action Required
pH Calibration Due	<ul style="list-style-type: none"> This reminder is displayed 12 months after the last successful pH Calibration. Calibrate the pH Sensor as per pages 14 and 15.
Change Pump Cassette	<ul style="list-style-type: none"> This reminder is displayed when the peristaltic dosing pump has exceeded 50 hours of operation since the last time the peristaltic pump cassette was changed. Change the Pump Cassette as per page 16.
General Messages	Explanation of Message
pH Drive v1.0 (c) 2019	<ul style="list-style-type: none"> This message is displayed each time the pH Drive is switched on. If you need to contact us for technical support, we may ask you the software version number ("v1.0" in this example).
Squeeze Tube:0:00Hr Calibrate in 365days	<ul style="list-style-type: none"> This message is displayed each time the pH Drive is switched on, after the version screen above. On this screen, the pH Drive displays the accumulated dosing pump operating time, and number of days since the last pH calibration.
Hardware Fail Messages	Explanation of Message
Initialising Clock Contact Service	<ul style="list-style-type: none"> The pH Drive has not been able to obtain data from the internal clock chip. Switch the pH Drive off for 5 seconds, then back on again. If the problem persists, return the unit for repair.
Hardware ERROR 3 Contact Service	<ul style="list-style-type: none"> This message can be error number 1 to 9. Switch the pH Drive off for 5 seconds, then back on again. If the problem persists, return the unit for repair.



Warranty

Maytronics Australia Pty Ltd (“Maytronics”) guarantees the **pH Drive** Controller (including inbuilt peristaltic pump) to be free from defects in material and workmanship when subjected to normal use and service. This is a replacement guarantee, whereby the faulty device is returned to Maytronics, or Authorised Dealer, freight prepaid within two years from the date of purchase.

Maytronics provides the same replacement guarantee for the pH Sensor, but limited to a period of one year from the date of purchase.

The squeeze tube inside the peristaltic pump, valves and fittings are not covered by this guarantee.

Acid must be diluted as instructed. Wear and damage caused by the use of undiluted acid is not covered by this warranty.

There are no expressed or implied warranties which extend beyond the face hereof, and Maytronics is not liable for any incidental or consequential damages arising from the use or misuse of this product. This limited warranty does not apply to any injury, loss, damage, defect or malfunction of the product or failure to function resulting from any failure to operate the product in accordance with the directions contained in the operating instructions, failure to function resulting from any accidents, acts of God, tampering, abuse, acts, omissions, or negligence by anyone other than Maytronics, including but not limited to such damage or injuries resulting from improper installation. Damage from excessive concentration of one or more chemicals is not covered by this warranty.

This limited warranty shall apply only to the Customer as an original purchaser. It is the customer's responsibility to follow safety regulations and laws regarding electrical installation. Shipping damage is not covered by this warranty.

No claims will be recognised without the proof of purchase. This warranty becomes invalid if unauthorised person or persons attempt modifications or repairs.

Any dispute between customer and Maytronics must be conducted in Queensland, Australia.



Contact Us

Maytronics Australia Pty Ltd
41 Bluestone Circuit
Seventeen Mile Rocks QLD 4073
AUSTRALIA

Tel 1300 693 657
Email..... infoau@maytronics.com
techau@maytronics.com
Web www.maytronics.com.au
ABN..... 87 148 058 495



maytroronics

The logo for Maytronics features the word "maytronics" in a lowercase, sans-serif font. The letter "o" is significantly larger than the other letters and is partially filled with a light blue color. A stylized, light blue wave graphic is positioned below the "o", extending from its left side and curving under it.