

WATER WITCH SMART SENSE



PRODUCT SUPPORT GUIDE

THE WATER WITCH SMART SENSE

Thank you for purchasing the Water Witch Smart Sense electronic water leveller. The Water Witch has been Australia's most trusted auto leveller for more than 25 years and we're excited to bring this new model to you. The Water Witch Smart Sense continues our promise of great reliability and now includes a host of added benefits.

The development of the original Water Witch harks back to the 1980s. As a pool builder I was frustrated with the poor quality and reliability of levellers at the time. Many prototypes were tested in my shed at home until we were comfortable we had developed the highest-quality leveller.

Many years of industry experience and talking to pool builders about what features they want in an auto leveller guided our development of the Water Witch Smart Sense. We're extremely proud of the new unit and its many additional features.

Importantly, the new Water Witch features full backward and forward compatibility with previous models. Any combination of Water Witch Control Box, Sensor and Solenoid will provide a great experience for your pool or water project.

As always, we promise to deliver the very best product to you. Thank you for your support and we trust your Water Witch will deliver many years of reliable service.



Cliff Cooke
Managing Director

INDEX

Compliance notices	Page 02
Product applications and warnings	Page 03
Product components and part numbers	Page 04
Control box installation	Page 05
Sensor installation	Page 06
Solenoid valve installation	Page 08
Alternative installation options	Page 10
Pump out from tank or trough	Page 12
Start-up process	Page 13
Operating modes	Page 15
Manual fill	Page 15
Runtime log	Page 16
Fault log	Page 16
Troubleshooting process	Page 17
Parameters	Page 19
Maintenance & specifications	Page 20
Warranty notice	Page 21

COMPLIANCE NOTICES

SOLENOID VALVE



WaterMark
Certificate of Conformity

Australian Certification Services Pty Ltd grants to the WaterMark Approved User:

Nymet Australia Pty Ltd
Trading as Nymet Australia Pty Ltd

the right to use the WaterMark as shown above in conjunction with the Certificate No. on product/s as identified in the WaterMark Schedule and as listed on the WaterMark database www.abcb.gov.au/Product-Certification/WaterMark-Certification-Scheme which have been shown to comply with the appropriate Applicable Specification referred to below and as amended from time to time. The WaterMark User is granted a licence to use the WaterMark subject to the rules governing the use of the WaterMark.

Product Type:	Solenoid Valve
Product Use:	Water Supply
Brand:	NYMET
Certification Specification/s:	WMTS 030:2016 Solenoid valves



Paul Greig
General Manager

Issue Date: 15th May 2019
 Initial Issue Date: 12th December 2005 (GlobalMark)
 Expiry Date: 2nd July 2023

Certificate No.: 4004

This Certificate is issued by a JAS-ANZ accredited certification body. The ABCB and JAS-ANZ do not in any way warrant, guarantee or represent that the product the subject of this Certificate conforms to the WaterMark Certification Scheme Rules, nor accept any liability arising out of the use of the product. The ABCB disclaims to the extent permitted by law, all liability (including negligence) for claims of losses, expenses, damages and costs arising as a result of the use of the product/s) referred to in this Certificate. The WaterMark Certification Scheme is a conformity assessment scheme based on ISO/IEC 17067. This Certificate may only be reproduced in its entirety.

Page 1 of 4



Australian Certification Services Pty Ltd ABN 37 121 022 366
 PO Box 67 Jamber, NSW 2238 AUSTRALIA
 Phone +61 2 8621 0736
 Email info@certification-services.com.au
 www.certification-services.com.au



Certification Number: 4004
 Issue Date: 15th May 2019
 Issue 01 Revision: 00

BACKFLOW PREVENTION VALVE



WaterMark
Certificate of Conformity

Australian Certification Services Pty Ltd grants to the WaterMark Approved User:

Nymet Australia Pty Ltd
Trading as Nymet Australia Pty Ltd

the right to use the WaterMark as shown above in conjunction with the Certificate No. on product/s as identified in the WaterMark Schedule and as listed on the WaterMark database www.abcb.gov.au/Product-Certification/WaterMark-Certification-Scheme which have been shown to comply with the appropriate Applicable Specification referred to below and as amended from time to time. The WaterMark User is granted a licence to use the WaterMark subject to the rules governing the use of the WaterMark.

Product Type:	Back Flow Prevention Devices
Product Use:	Water Supply
Brand:	NYMET
Certification Specification/s:	AS/NZS 2845.1:2010 Water supply—Backflow prevention devices Part 1: Materials, design and performance requirements



Paul Greig
General Manager

Issue Date: 3rd July 2018
 Initial Issue Date: 27th March 2017
 Expiry Date: 2nd July 2023

Certificate No.: 40070

This Certificate is issued by a JAS-ANZ accredited certification body. The ABCB and JAS-ANZ do not in any way warrant, guarantee or represent that the product the subject of this Certificate conforms to the WaterMark Certification Scheme Rules, nor accept any liability arising out of the use of the product. The ABCB disclaims to the extent permitted by law, all liability (including negligence) for claims of losses, expenses, damages and costs arising as a result of the use of the product/s) referred to in this Certificate. The WaterMark Certification Scheme is a conformity assessment scheme based on ISO/IEC 17067. This Certificate may only be reproduced in its entirety.

Page 1 of 2



Australian Certification Services Pty Ltd ABN 37 121 022 366
 PO Box 67 Jamber, NSW 2238 AUSTRALIA
 Phone +61 2 8621 0736
 Email info@certification-services.com.au
 www.certification-services.com.au



Certificate Number: 40070
 Issue Date: 3rd July 2018
 Issue 02 Revision: 00

PRODUCT APPLICATIONS AND WARNINGS

The Water Witch is used in many different applications and projects to maintain a minimum or maximum water level. Some of the most popular applications include:

- Swimming pools and spas
- Water features and ponds
- Water / Splash parks
- Irrigation projects
- Balance tanks
- Infinity edge troughs
- Commercial pools
- Water tanks

Given the many suitable applications for the Water Witch, a quality installation is required to ensure performance is not affected by site conditions or any other factor.

Please note the following important project considerations:

- The Water Witch is manufactured and tested to the highest international standards. Wear and onsite conditions, however, may cause component failure. All installations must include sufficient overflow provisions to ensure a flooding event does not occur.
- Indoor pools and enclosed projects must also feature sufficient overflow provisions to avoid a potential flooding event.
- Contact your local water authority to confirm whether your proposed Water Witch supply side installation complies with the relevant water regulations.
- Individual components may need to be replaced in the future. All installations should incorporate provisions for easy part replacement.
- The Water Witch includes wearing components that may fail or be affected by onsite conditions. A visual inspection of all components is required at least every month to ensure the unit is operating correctly.
- The Water Witch is approved for indoor and outdoor use. However, consider what effect the environment may have on the unit when deciding on an installation location.

PRODUCT COMPONENTS AND PART NUMBERS

The reliability and durability of the Water Witch is founded on its simplicity – there are just three main components and the unit will work well if all components are functioning correctly and site conditions are suitable.

CONTROL BOX

WS345 Water Witch Control Box



SENSOR

- WS355 Water Witch Sensor Only – 5m
 - WS356 Water Witch Sensor Only – 20m
 - WS357 Water Witch Sensor Only – 30m
 - WS358 Water Witch Sensor Only – 40m
 - WS359 Water Witch Sensor Only – 50m
 - WS360 Water Witch Sensor Only – 60m
-



SOLENOID VALVE

- WS320 Water Witch Solenoid Only
 - WS330 Water Witch Solenoid Cable Only
 - WS335 Water Witch Solenoid & Cable
 - WS340 Water Witch Backflow Prevention Valve
-



Note – Special order options are available for sensors up to 250m long.

CONTROL BOX INSTALLATION

The Control Box is the brain of the operation, continuously receiving signals from the Sensor to confirm whether the body of water is at the required level or if water needs to be added to the project.

INSTALLATION PROCESS AND CONSIDERATIONS:

- Position the unit at least 1.2m above ground level and ensure a consistent power source is within reach of the power lead.
- Secure the control box to the desired position on a wall or post with the screws provided.
- Secure the power pack to the wall or post with the screws provided.



NOTE: The Control Box is approved for indoor and outdoor use. However, locating the Control Box and power pack so they are protected from the weather will extend their serviceable life.

Product Support Guide

INSTALLATION PROCESS AND CONSIDERATIONS:

- The sensor requires a 50mm class 9 or class 12 PVC pipe to be installed as a balance line from the project's wall to the pump and filter area. **ALWAYS USE 50MM PIPE FOR THE SENSOR HOUSING TO ENABLE ADEQUATE FLOW AROUND THE SENSOR AND FUTURE SERVICABILITY.**
- **THIS PIPE MUST BE PLACED AT LEAST 300MM BELOW WATER LEVEL** and can be dressed with a push-in eyeball to match the project's other wall fittings.
- The pipe is usually run along the suction and return trench and elbowed up within the equipment area. **THIS PIPE MUST BE LEVEL TO AVOID AIR LOCKS** which will affect flow and performance.
- A 50mm cap is provided to cover the sensor pipe housing and protect the Sensor from dust, debris, pests and foreign materials. The cap fits neatly onto the 50mm sensor pipe housing.
- **DO NOT GLUE THE CAP TO THE SENSOR HOUSING PIPE.**
- If the Sensor is to be located away from the equipment area, **ALWAYS RUN THE LEAD THROUGH ADEQUATELY SIZED CONDUIT THAT WILL ENABLE THE COMPLETE SENSOR TO BE REPLACED AT A LATER DATE.**
- **NEVER CUT EXCESS SENSOR CABLE.** Roll excess cable and bind together with the Velcro straps provided.

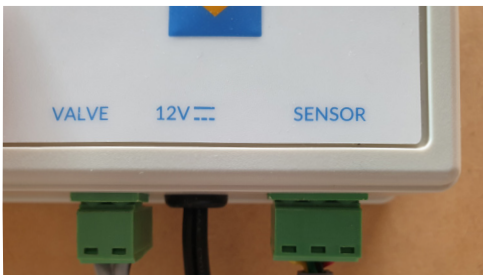

NOTE: Sensor and Solenoid plugs must face backwards when inserted into the new Water Witch Control Box.

SOLENOID VALVE INSTALLATION

The Solenoid is regulated by the Control Box. When the water level is low the Control Box sends a 24V AC current to open the Solenoid so water flows in to the project. The Solenoid will close when the water level is restored to the correct level.

Solenoid cables up to 100m long are available by special order.

INSTALLATION PROCESS AND CONSIDERATIONS:

- Install Backflow Prevention Valve and Solenoid into water supply/fill line, ensuring arrows are pointed in the direction of the water flow. Connect Solenoid Cable to the Solenoid and Control Box.

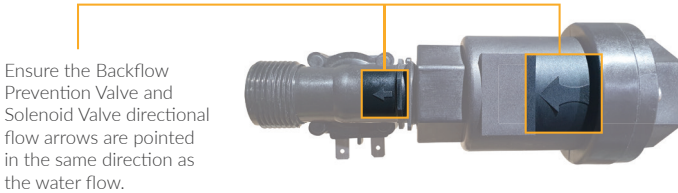

OPTION 1 Solenoid installed into balance line

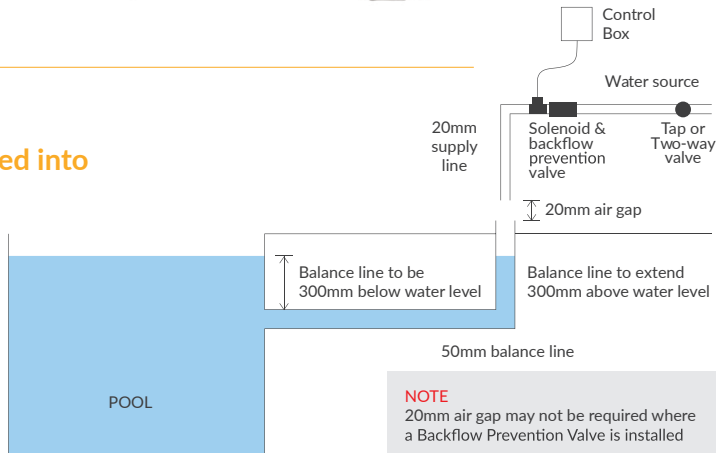

OPTION 2 Solenoid installed into filtration return line

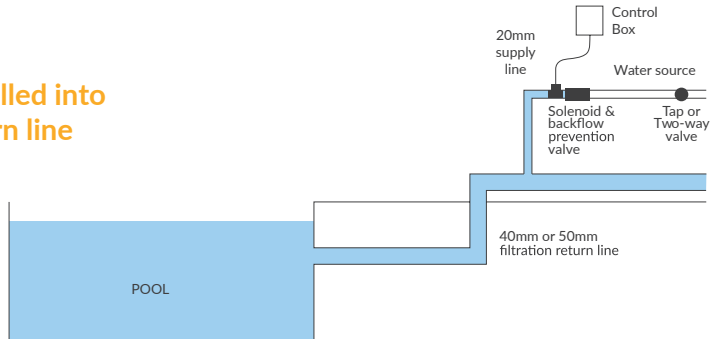

- A TAP OR TWO-WAY VALVE MUST BE PLACED BEFORE THE SOLENOID TO ENABLE THE WATER SOURCE TO BE TURNED OFF AT ANY TIME.
- Standard installation positions the supply line 20mm above the fill balance line without a hard connection (An air gap is required to ensure the water from the project cannot contaminate the water source). **THE FILL FLOW RATE MUST NOT EXCEED THE RATE THE BALANCE LINE TRANSFERS WATER INTO THE PROJECT.**
- If approved in your local area, the fill line can be plumbed into the filtration return line. If installing in this manner, **A BACKFLOW PREVENTION VALVE MUST BE INSTALLED BETWEEN THE SOLENOID AND THE WATER SOURCE TAP.**
- The solenoid requires an operating pressure range of 29-116 PSI (200-800 kPa). **ENSURE THE ONSITE PRESSURE IS SUITABLE FOR CORRECT OPERATION OF THE SOLENOID.** Install a pressure limiting valve on the water supply line if the onsite pressure is greater than 116 PSI (800 kPa).

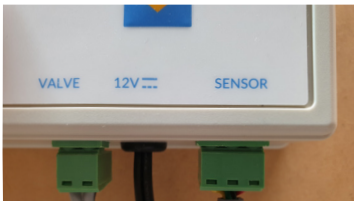

NOTE: Sensor and Solenoid plugs must face backwards when inserted into the new Water Witch Control Box.

The solenoid is a wearing component with an indefinite operating life. Your project should include suitable overflow provision in case of possible solenoid failure.

ALTERNATIVE INSTALLATION OPTIONS

BALANCE TANK

The Water Witch is the most effective auto leveller for balance tank installations.

Maintaining a minimum water level in the balance tank will ensure the pump and pool equipment is protected whilst also allowing for the high water level fluctuations caused by bather activity and excess rainwater.

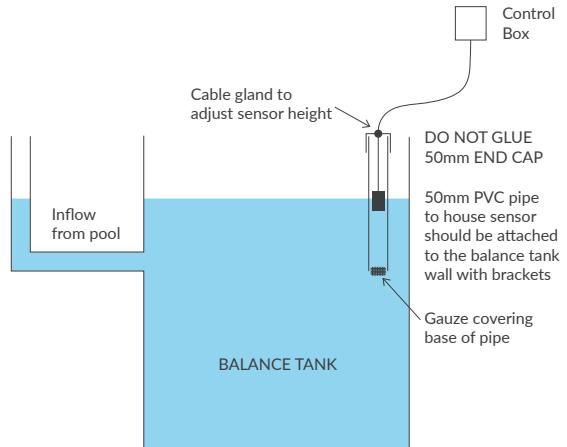

INSTALLATION CONSIDERATIONS:

- The Sensor should be housed inside 50mm class 9 or class 12 PVC pipe attached to the wall of the balance tank. Fasten the pipe to the wall with brackets, ensuring there is enough clearance at the top to attach the Sensor end cap.
- Run the Sensor cable through appropriately-sized conduit to ensure the Sensor can be accessed for serviceability and replaced if required.
- Small debris capable of affecting sensor performance can build up inside balance tanks. It is advisable to protect the sensor from small debris by covering it with a silt sock or stocking. Alternatively, cover the base of the sensor pipe housing with gauze so debris is blocked while water can still move freely.
- An overflow provision will need to be installed at the maximum water height inside the balance tank.
- **The water FILL LINE should be directed to the highest body of water so it is kept full and the excess then cascades into the balance tank.**

PUMP OUT FROM TANK OR TROUGH

The Water Witch Smart Sense can be installed to pump water out of a tank, trough or any other water body.

Instead of activating the fill function when the water level is low, programming and an alternative installation enables the Water Witch to activate a pump when the water level increases to a set height. The pump will continue operating until the water level drops back below the sensor level.

OPERATING PROCESS:

- Sensor recognises when the water level increases to the preset maximum height
- Control Box activates relay switch
- Power passes through relay switch and activates pump
- Pump continues to operate until water drops below sensor level

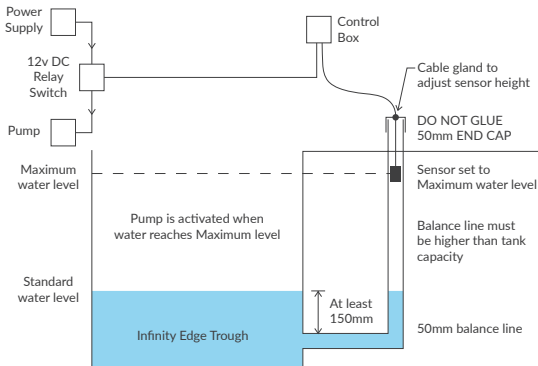

NOTE: A licensed electrician will be required to build a junction box incorporating the 12v DC Relay Switch.

START-UP PROCESS

It's now time to start your Water Witch. Complete the following process to test your unit and confirm all components are operating correctly:

SET SENSOR LEVEL

- Fill the pool or water body to the required water level
- Turn on power and water supply to Water Witch.
- Press **MODE** until you reach the **SET LEVEL** function.
- Confirm Sensor height is correct by checking the **SCAN / FILL** operation when lifting the Sensor up and down.
- Press **ENTER** to confirm.



When the water level is at the fill line the SCAN icon will be displayed.

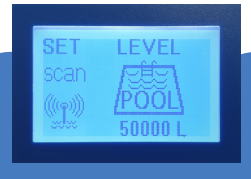

When the water level is below the fill line the FILL icon will be displayed.



If you do not press **ENTER** to confirm the sensor level the unit will remain in **SET LEVEL MODE**.

After being left in this mode for 30 minutes the unit will trigger a fault and stop operating.

waterwitch

Electronic Water Leveller

Tank Type	Suitable Applications	Minimum Volume (Litres)	Maximum Volume (Litres)
Pool 	Domestic or small commercial pools	10,000 L	500,000 L
Pump Out 	Used to pump water out of a tank or trough	N/A	N/A
Comm 	Commercial pools and large projects	100,000 L	5,000,000 L
Other 	Water features, ponds or holding tanks	1,000 L	100,000 L
Balance Tank 	Balance tanks and infinity edge troughs attached to pools or water features Capacity of tank or trough Capacity of pool or water feature	1,000 L 10,000 L	100,000 L 500,000 L
Spa 	Spa or small indoor heated pool	1,000 L	50,000 L

NOTE - in **BALANCE TANK** mode you will need to set the correct water volume for both the pool and trough.

OPERATING MODES

The Water Witch Smart Sense includes six operating modes to ensure there is an option to suit your particular pool, spa or water project.

The following process is used to set the correct TANK TYPE and TANK VOLUME.

SET OPERATING MODE

- Press **MODE** twice to enter the **SET TANK TYPE** screen
- The current tank type option will flash
- Press **↑** or **↓** key to select the most appropriate mode for your project
- Press **ENTER** to accept the correct operating mode
- Press **↑** or **↓** key to adjust the volume of water for your project
- Press **ENTER** to accept the correct water volume

MANUAL FILL

Manual Fill Mode is used to add water to a pool or project for a set period of time or until the water level reaches the sensor height.

SET MANUAL FILL

- Press **MODE** three times until you reach the **SET MANUAL** function.
- Press **↑** or **↓** to set the required fill time
(Adjust by 10min increments to a maximum of 48 hours).
- Press **ENTER** to confirm fill time and begin countdown timer.
- When the fill process is complete, press **MODE** to return to **AUTOMATIC** mode.

The water level must be low for this function to operate correctly. Take care to correctly estimate the required fill time and ensure the sensor is free of debris to prevent potential water damage onsite.

RUNTIME LOG

The Runtime Log provides a mean average and daily summary of the unit's runtime for the previous 14 days.

VIEW RUNTIME LOG

- Hold **ENTER** for three seconds to open the Runtime Log.
- The first figure you will see is the average daily runtime for the past 14 days.
- Press **↑** or **↓** to scroll through the daily runtime for each of the past 14 days.
- The current 24 hour period is displayed as TODAY-00 and each 24 hour period prior to that is recorded as TODAY-01, TODAY-02 etc. in sequence.
- Press **MODE** to return to **AUTOMATIC** mode.

All days referred to in the log are complete 24 hour periods.

FAULT LOG

The Fault Log provides details of the last six faults recorded by the unit.

VIEW FAULT LOG

- Hold **↓** and **ENTER** for three seconds to open the Fault Log.
- Press **↑** or **↓** to scroll through the faults recorded in the unit's log.
- For details of fault codes and descriptions refer to the fault table in the Troubleshooting section of this guide.
- Press **MODE** to return to **AUTOMATIC** mode.

TROUBLESHOOTING PROCESS

The Water Witch is an accurate and reliable electronic auto leveller which should provide you with many years of consistent performance.

If your Water Witch is not operating correctly upon installation or you suspect a fault after years of reliable service, you will need to consider the problem being experienced and refer to the fault table below:

Fault No.	Description	Details			
1	FILL	<p>The fill timer has exceeded its maximum run time. Consider the following possibilities:</p> <ul style="list-style-type: none"> • Debris may be caught in sensor so it doesn't recognise full water level – check and clean sensor to ensure it operates correctly. • Sensor has failed and does not recognise full water level – check the sensor operation and replace if required. • Solenoid valve has failed and is not filling the pool. This will be recognisable by a low water level. Replace the solenoid valve and check the unit is operating correctly. • Volume is set too low and fill timer exceeds run time before full water level is attained – check volume is correct for the water body. Alternatively, if this fault occurred because a large volume of water was removed from the pool, use the Manual Fill feature in the future. • Sensor wiring is incorrect – check sensor plug is inserted correctly and wiring to the three pins is as per the following: <div style="display: flex; align-items: center; justify-content: center; margin: 10px 0;"> LEFT <table border="1" style="border-collapse: collapse; text-align: center;"> <tr> <td style="padding: 5px;">YELLOW</td> <td style="padding: 5px;">GREEN BLACK</td> <td style="padding: 5px;">RED</td> </tr> </table> RIGHT </div> <ul style="list-style-type: none"> • Air-lock in the sensor balance line – check water level in the balance line relative to the pool level. 	YELLOW	GREEN BLACK	RED
YELLOW	GREEN BLACK	RED			

waterwitch

Electronic Water Leveller

Fault No.	Description	Details
2	MODE	The unit has been left in SET LEVEL MODE or MANUAL FILL MODE for too long – set the unit to the correct operating mode.
3	VALVE	The control box output voltage does not suit the requirements of the solenoid valve - check the valve output type within the Parameters settings and change if required.
4	NO VALVE	The unit does not detect a solenoid valve being connected to the Water Witch – check the solenoid and cable for any damage to the wire or connectors.
5	BOOST	The output voltage is unable to open the solenoid valve – check the valve output type within the Parameters settings and change if required. Contact Cooke Industries if the issue persists.
6	OUTPUT	A short circuit is detected at the solenoid valve connection – replace the solenoid valve.
7	UNKNOWN	This is typically a program or memory fault – reset the unit's power and contact Cooke Industries if the issue persists.

Press **ENTER** to return to standard operating mode after you have taken the necessary steps to rectify an issue.

An alternative issue that you may experience is a failed solenoid valve which continuously fills the pool. If this occurs you will not have a fault log at the Control Box because this issue is the result of the solenoid leaking. This could be because of a split diaphragm inside the solenoid or the solenoid valve has failed in the open position. Replace as required.

The Solenoid Valve is a wearing component which will deteriorate with time and use. At some point in the life of the unit it will fail and need to be replaced.

PARAMETERS

There are a number of parameters which can be adjusted to improve the operation of the unit in relation to onsite conditions, connected hardware or display settings.

ADJUST UNIT PARAMETERS

- Hold **↑** and **ENTER** for three seconds to open Parameters
- Press **↑** or **↓** to scroll to the required Parameters section.
- Press **ENTER** to view the Parameters options.
- Press **↑** or **↓** to scroll to the appropriate Parameters setting.
- Press **ENTER** to confirm the appropriate Parameters setting.
- Press **MODE** to exit Parameters and return to **AUTOMATIC** mode.
- **A complete 10 second power off and power on cycle is required to ensure the new Parameters settings are saved within the unit's memory.**

Code	Parameter	Code	Name	Description
1	OUTPUT	0	SOL 24V AC	24V AC Solenoid
		1	SOL 12V DC	12V DC Solenoid
		2	SOL COMM	Commercial grade 24V AC Solenoid
		3	RLY 12V DC	12V DC Relay Switch
2	VOL UNITS	0	LITRES	Volume displayed in Litres
		1	GALLONS	Volume displayed in Gallons
3	SENS TIME	0	3 SEC	Sensor reaction time is 3 Sec
		1	6 SEC	Sensor reaction time is 6 Sec
		2	9 SEC	Sensor reaction time is 9 Sec
		3	12 SEC	Sensor reaction time is 12 Sec

MAINTENANCE AND SPECIFICATIONS

Most Water Witches operate reliably for at least 5-10 years under normal operating conditions. The following maintenance schedule should be adopted to optimise the unit's serviceable life:

- **Monthly** – Observe and inspect all components to ensure the unit is operating correctly. Particular care should be taken during the first month after installation to ensure the system is operating correctly.
- **Half-yearly** – Inspect the Sensor to ensure it is free of debris, the ball moves freely within the Sensor and the Sensor activates the Control Box as required.
- **Annually** – Remove the solenoid pre-filter to clear any debris or contaminant.

Maintenance checks should be conducted more regularly for commercial applications.

Product	Water Witch Electronic Water Leveller
Control Box	
Power	12V DC Power Pack, supplied via 240V AC
Weight	180g
Dimensions	140mm x 80mm x 40mm
Sensor	
Sensor weight (excluding cable)	130g ± 10g
Sensor cable length	5m, 20m, 30m, 40m, 50m or 60m Special order sensors are available up to 250m
Solenoid	
Solenoid cable length	5m (Special order solenoid cables are available up to 100m)
Plumbing connection	20mm male thread on inlet and outlet
Power	24V AC
Operating pressure	29-116 PSI, 200-800 kPa
Ambient conditions	Ambient temperature: 2° to 60° Celsius Relative humidity: 0% to 100% Water temperature: 2° to 80° Celsius

WARRANTY NOTICE

Cooke Industries will provide a new or repaired part or component at its discretion in place of any part or component, which is found upon inspection, to be defective in material or workmanship during the warranty period.

Said part or component will be repaired or replaced without charge to the initial user during normal working hours at the place of business of Cooke Industries or a Cooke Industries nominated distributor upon the consent of Cooke Industries.

This warranty does not apply to failure occurring as a result of abuse, misuse, negligent installation or repair and/or alterations or modifications whatsoever made to the product without the express written consent of Cooke Industries. This also extends to outside influences or site conditions which may impede or obstruct the correct functioning of the unit.

Warranty claims are to be lodged at www.cookeindustries.com.au/warranty

Please note the user must submit the serial number and proof of purchase to make a claim under this warranty.

SPECIAL CONDITIONS

1. Onsite labour, service call or freight charges to return items to Cooke Industries are the responsibility of the purchaser.
2. Under no circumstances whatsoever shall Cooke Industries be liable for incidental or consequential damages, inconveniences or expenses in connection with the removal or replacement of this product.
3. In circumstances whereby it has been deemed that the installer has clearly not followed the steps and information as set out in this guide (negligent installation), the warranty will become null and void.
4. Under no circumstances will Cooke Industries be liable for damage caused to persons or property as a result of the incorrect installation or misuse of this product.



waterwitch

Electronic Water Leveller

Cooke Industries
P: 1300 652 076
E: info@cookeindustries.com.au
cookeindustries.com.au

**COOKE**
INDUSTRIES