



B Residential
RANGE

B Fresh
POOL WATER SYSTEM
MODEL 70

B Mineral
POOL WATER SYSTEM
MODELS 50 | 90 | 150

Instruction Manual

B BRAUER
SWIM

Thanks for choosing the Brauer Swim B-Fresh / B-Mineral System!

Built for exceptional performance and long-lasting reliability, this system is designed to make pool care easy and effective. Follow the steps in this manual to get the best from your system, with essential tips and troubleshooting advice included to keep things running smoothly.

If you ever need assistance, just reach out to your Brauer Swim Certified Partner or visit our website for support. Enjoy a fresher, cleaner pool experience with Brauer Swim!

Cautions & Warnings	04
Getting to know your system	05
Installation Guide	11
Control unit installation	
Cell Assembly Installation	12
Ozone injection manifold installation	
Control unit operation	
Important Installation Information	13
Cell Assembly Installation	
Gas Trap	
Pump Outlet Socket	
Operating Instructions	14
Master Switch	
Mineral/Salt Requirements	
Achieving The Correct Mineral/Salt Levels	
New Pool Installations	
Existing Pool Installations	
Timer Setting	
Cell Output Control	
Cell Output Display	
Recommended Water Balance	21
Maintenance	21
Control Unit	
Water Balance	
Cell Cleaning	
Cell Replacement	
Ozone Injection Manifold	
Teflon Check Valve Replacement	
Internal Manifold Check Valve Set Replacement	
Maintenance Logbook	24
Warranty Information	26
Warranty Registration	28
Troubleshooting	
Product support	
Product Specifications	30
Contact us	
Model & Serial Number Information	31

READ AND FOLLOW ALL INSTRUCTIONS. IMPORTANT SAFETY INSTRUCTIONS PERTAINING TO A RISK OF FIRE, ELECTRIC SHOCK, OR INJURY TO PERSONS.

- This manual contains important information about the operation and safe use of the system.
- Please read the instructions fully and keep this manual on hand whenever operating or maintaining your system.
- As for all pool equipment and chemicals, the system should be installed out of reach of children. Children must not have access to operating the system without adult supervision.
- The system must be installed by Brauer Swim or an Certified Partner. This system may not perform as expected if installed incorrectly.
- Failure to correctly install may result in damage to the system which will void the warranty.
- Control Unit must not be installed in the pool zone as defined by AS/NZS3000.
- Ensure that you have dry hands when operating the system.
- Although the system has a weather resistant design, its service life will be considerably longer if it is not exposed to direct sunlight and rain. Wear and tear from direct exposure to the elements is not covered by the warranty.
- Do not allow grass or weeds to grow around the system, or the tubing and cables to prevent accidental damage from garden trimming equipment.
- Do not open the Control Unit.
- Any damaged cables must be replaced immediately by Brauer Swim or an Certified Partner to prevent electrical shock.
- If the Mains Power Lead (supply cord) is damaged, it must be replaced by the manufacturer or its service agent or similarly qualified person to avoid a hazard.
- Unplug the Control Unit Main Power Lead before servicing or changing the Cell.
- The system must be serviced only by Brauer Swim or an Certified Partner.
- Do not operate Cell without proper flow or water circulation as this may cause damage to the system.
- Water chemistry needs to be regularly tested and adjusted if necessary.
- The system is not intended for use with temporary, foldable, or storable pools. All pipework associated with this system is intended to be fixed and should remain intact.
- This product is not intended for use by persons (including children) with reduced physical, sensory or mental capabilities, or lack of experience and knowledge, unless they have been given supervision or instruction concerning the use of the appliance by a person responsible for their safety. Children should be supervised to ensure they do not play with the product.
- The system contains sharp parts, particularly around the edges of the heatsink on rear of the Control Unit. Please handle system with care using protective gloves.
- The Control Unit is very heavy (approx. 20-25kg). Safe lifting practices and correct installation is necessary to avoid injury or damage.

CONTROL UNIT

Front View

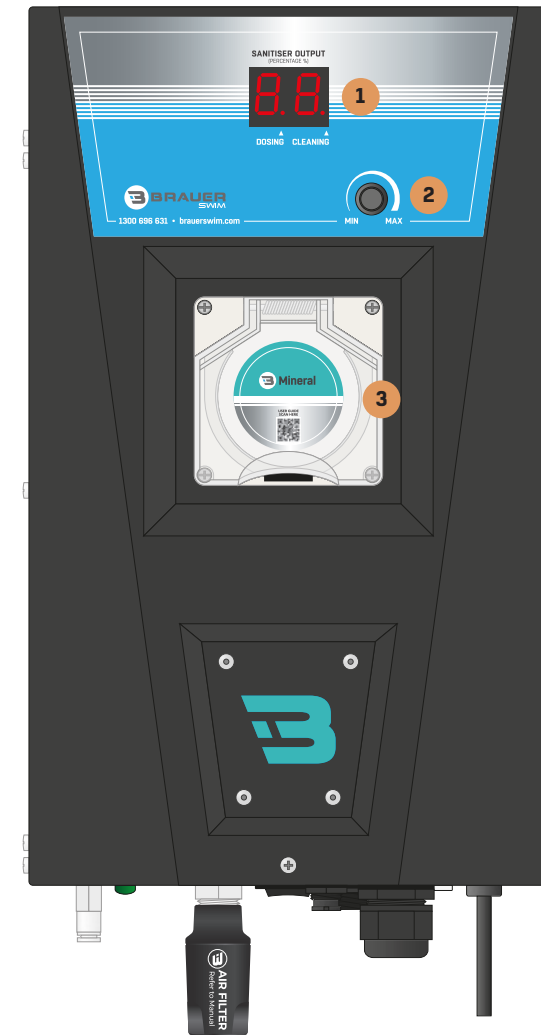

1	Cell Output Display (Range 0%-99%)
2	Cell Output Control Dial
3	Digital Timer

Bottom View

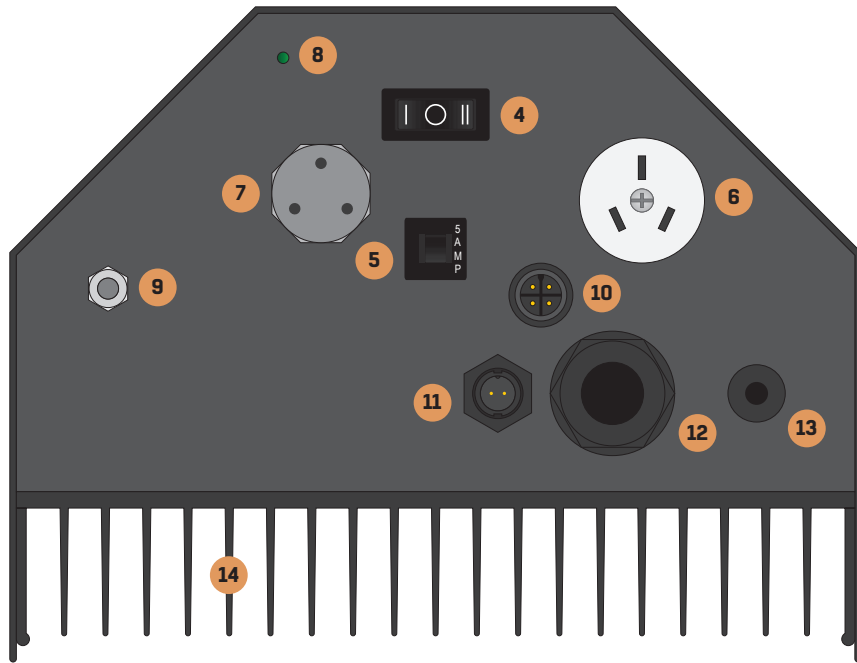

4	Master Switch (Auto/Off/Manual)
5	Circuit Breaker
6	Pump Outlet Socket (Max 7.5 Amps)
7	Ozone Air Filter
8	Ozone Indicator Light
9	Ozone Output (Push Fitting)
10	pH Control (12v Supply)
11	External Control (Commercial Only)
12	Cell Lead
13	Mains Power Lead
14	Heat Sink

CONTROL UNIT MOUNTING BRACKET

Front View

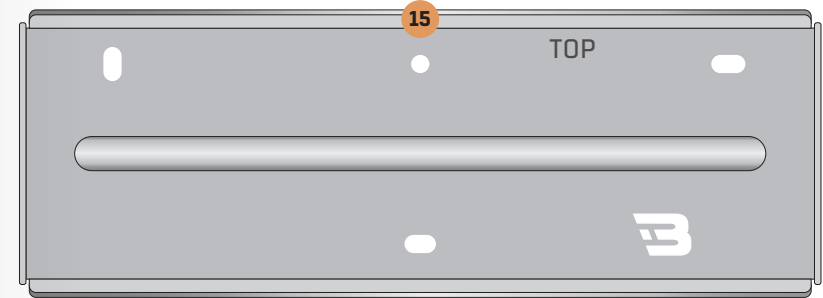

15	Control Unit Mounting Bracket
----	-------------------------------

CELL ASSEMBLY

Side View

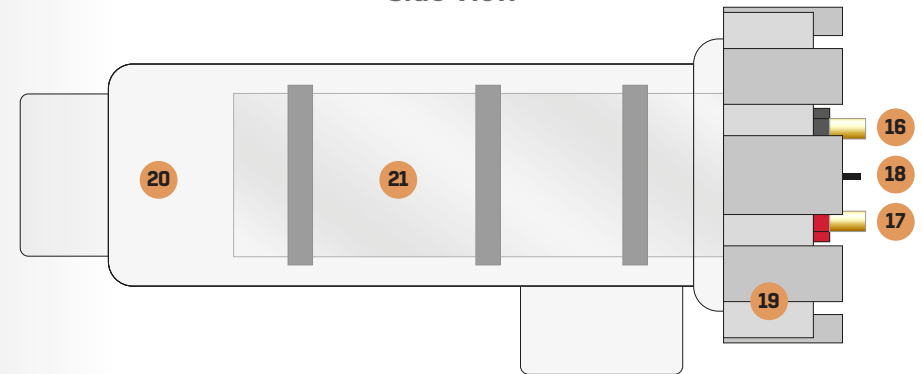

16	Cell Terminal Negative (Black)
17	Cell Terminal Positive (Red)
18	Cell Terminal Gas Sensor (Blue)
19	Cell End Cap
20	Cell Housing
21	Cell

Getting to know your system

CELL LEAD

Side View

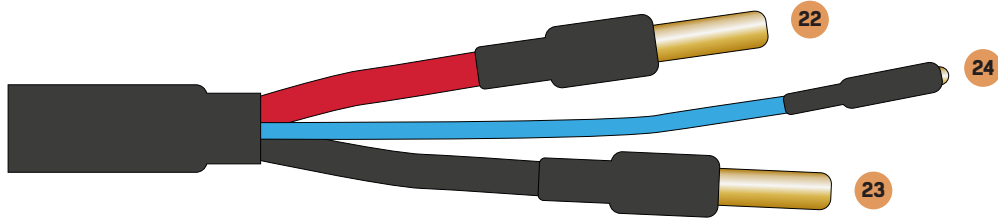

22	Cell Lead Connector Positive (Red)
23	Cell Lead Connector Negative (Black)
24	Cell Lead Connector Gas Sensor (Blue)

OZONE INJECTION MANIFOLD

Side View

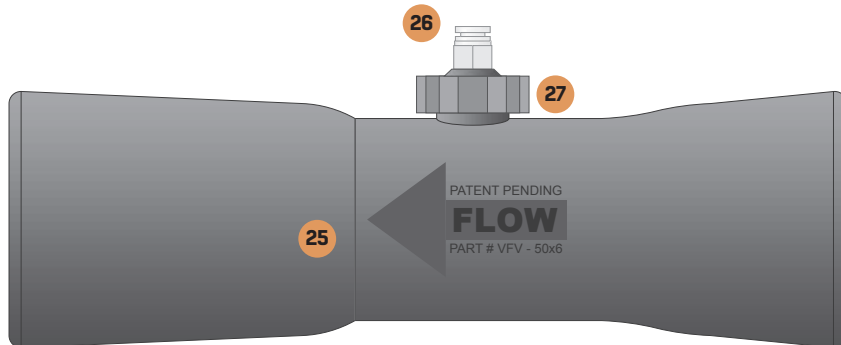

25	Ozone Injection Manifold
26	Ozone Input (Push Fitting)
27	Manifold Screw Fitting

Getting to know your system

MANIFOLD CHECK VALVE SET (INTERNAL)

Side View

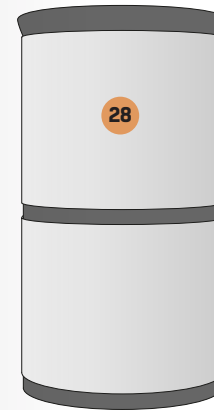

MANIFOLD CHECK VALVE SET (INTERNAL)

Top View



28	Manifold Check Valve Set (Internal)
----	-------------------------------------

TEFLON TUBING WITH CHECK VALVE

Side View

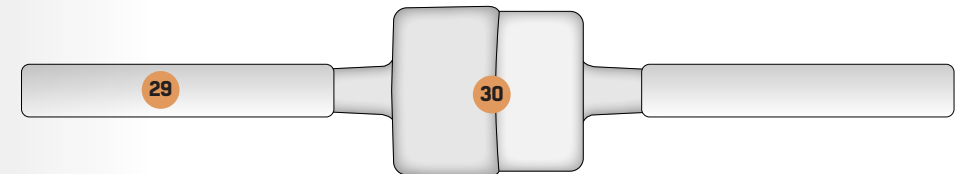

29	Ozone Teflon Tubing
30	Ozone Teflon Tubing Check Valve

Getting to know your system

MAINTENANCE PACK

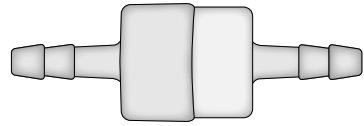

PART	
Teflon Check Valve Replacement	

QTY	REPLACEMENT SCHEDULE
2	Every 12 months or as required

PART	
Ozone Air Filter Media Replacement	

QTY	REPLACEMENT SCHEDULE
5	Every 6 months or as required

SETUP PACK

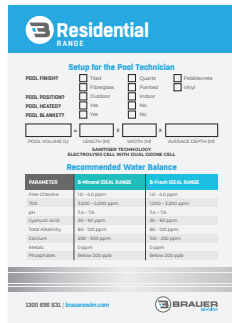

Water Balance Set-Up Card



Support and Warranty Registration Card

Installation Guide

THIS SYSTEM MUST BE INSTALLED BY A BRAUER SWIM CERTIFIED PARTNER.

Please note: If your pool has an integrated spa, you may require a degas vessel if the return to pool goes to the spa first. For further information contact your Brauer Swim Certified Partner or visit our website.



Control unit installation

- 1 Mount Control Unit a maximum of 1.5 meters from the Cell Assembly. Fit Control Unit Mounting Bracket on the wall. Install the Control Unit a minimum of 900mm above ground level outside the pool ozone as defined by AS/NZS3000 in an area protected from the elements to eliminate possible damage from severe weather conditions.

Cell assembly installation

2	Plumb Cell Assembly onto return pipe after filter, ensuring there is a gas trap (See Gas Trap information below).
3	Connect the Cell Lead Connectors to the three colour coded Cell Terminals located on Cell. (Terminals need to be tight). Do not use anti-corrosive spray i.e. Inox or WD-40, etc.

Ozone injection manifold installation

4	Plumb Ozone Injector Manifold after the Cell Assembly on the return line of the pool return ensuring direction of the flow through the Manifold is correct. The Manifold should be last on the pool return line, after all other equipment installed.
5	Connect supplied white Ozone Teflon Tubing With Check Valve (see labels on Ozone Teflon Tubing for direction ensuring non-return Check Valve is in the correct direction) onto the Control Unit Ozone Output and the Ozone Injector Manifold Ozone Input by connecting to the push fittings.
6	Leave plumbing to cure for a 24-hour period for best results.

Control unit operation

7	Plug pump power lead into Control Unit Pump Outlet Socket (See Pump Outlet Socket information below). Turn Control Unit ON to "manual" (See Master Switch information below). Check all plumbing for visible leaks.
8	Set Timer on Control Unit to the desired run time (see Timer Setting information below).
9	Adjust the Cell Output Control Dial to the desired output (See Cell Output Control information below). Note: We recommend running your system at maximum output (99) for the first week of operation for new pool installations.
10	Set the Master Switch to the "Auto" position.
11	Ensure appropriate mineral or salt levels are achieved and dissolved. (See Mineral/Salt Requirements below).
12	Ensure that the pool water is correctly balanced. (See Recommended Water Balance information below).

Important installation information

CELL ASSEMBLY INSTALLATION

The Cell Assembly must be plumbed into the return line after the filter. In situations where a heater is incorporated, the Cell Assembly should be installed after the heater. Should a solar heating system be installed, the Cell Assembly must be plumbed after the solar diverters and after the water exits the solar system and re-joins the mainstream pool return line. Ensure there is a gas trap (see Gas Trap below).

GAS TRAP

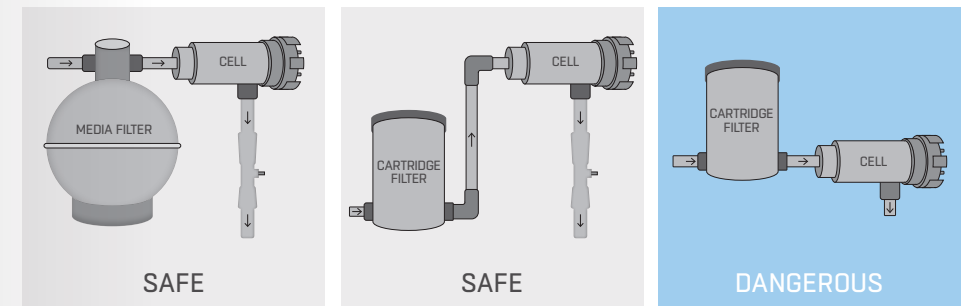

PUMP OUTLET SOCKET

A 240 volt Pump Outlet Socket is supplied and located on the underside of the Control Unit. Your pool pump power supply lead should be plugged in to the Pump Outlet Socket so that when the Timer switches at the designated times both the Control Unit and the pump will operate together.

The Pump Outlet Socket is designed to operate a single pool pump of **maximum 1.5 hp (horsepower) or 7.5 Amps only**. Do not attempt to operate any equipment other than your pool pump from this socket as damage might occur to the Control Unit and void your warranty.

MASTER SWITCH

 AUTO		Auto	The Timer will automatically switch the system on or off at your designated times.
○ OFF	0	Off	The system will not operate.
 MANUAL		Manual	The Timer is by-passed, the system will operate all functions permanently.

MINERAL/SALT REQUIREMENTS

All systems require certain mineral or salt levels. Please refer to system TDS specifications (B-Mineral models TDS is 3500-4500ppm and B Fresh model TDS is 1200-3500ppm). Using only refined swimming pool minerals or salt, add the desired quantity to the swimming pool water. To assist in the rapid dissolving and mixing, sweep or brush the solids until they are fully dissolved.

Note: Bunnings sells a mineral bag Mag Sulphate, which will increase the TDS but is no good for sanitation production.
Warning: Undissolved mineral or salt may result in staining of your pool's interior. Never add via the skimmer box. Please follow mineral or salt manufacturers instructions when adding.

ACHIEVING THE CORRECT MINERAL/SALT LEVELS

For best results, the mineral or salt concentration in the pool water is required to be within the systems specifications. These figures are temperature dependant. In summertime as temperature rise mineral or salt levels may require slight reduction while in wintertime the reverse may be true to allow optimum performance of the system.

NEW POOL INSTALLATIONS

It is essential that new pool water is balanced correctly. Consult your local pool technician on how do this. You can find the recommended water chemistry parameters in the recommended Water Balance Chemistry section following.

1	If Control Unit is not operating, set the Master Switch to "Manual" position to turn the Control Unit ON.
2	Set the Cell Output Control Dial to 00.
3	Once the mineral or salts have been added and dissolved turn the Cell Output Control Dial to the required percentage (0-99) based on the season and the size of the pool (set to max output for the first week of operation and adjust down as required).
4	Set the Master Switch to "Auto" position.

EXISTING POOL INSTALLATIONS

To establish the mineral or salt level in an existing pool, take a water sample to your local pool technician for testing, they will tell you the current mineral or salt levels and advise the correct course of action required.

1	If Control Unit is not operating, set the Master Switch to "Manual" position to turn the Control Unit ON.
2	Set the Cell Output Control Dial to 00.
3	Once the mineral or salts have been added and dissolved turn the Cell Output Control Dial to the required percentage (0-99) based on the season and the size of the pool (set to max output to start with and adjust down as required).
4	Set the Master Switch to "Auto" position.

TIMER SETTING

Summer Settings

Ideally, run for 4 hours in the morning (6am-10am) and 4 hours in the evening (4pm-8pm). For a smaller pool you can run less hours. In extreme weather it may be necessary to run longer hours. Contact your local pool Professional for further assistance.

Winter Settings

In winter you should lower your running time by up to 50% of your summer setting depending on your free chlorine levels. Ideally, you should run 2-3 hours in the morning and 2-3 hours in the evening. This preserves and extends the life of your equipment.

IMPORTANT: The Timer Switch will override the timer when it is in the Manual position. For timer settings to control the unit the Timer Switch needs to be in the AUTO position.

Setting your XR Timer



These are the functional Buttons and display on your timer:

TIMER	Program review and setting programs
MANUAL	To select "ON/AUTO/OFF" Modes
CLOCK	To adjust current DAY and TIME
DAY	To adjust the day of the week
HOUR	To adjust the hour
MINUTE	To adjust the minute
	Reset Timer's settings
LED	To indicate ON/OFF status



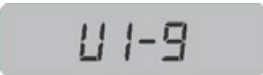

How to reset the Timer & Perform Software Version Check

Press the  button with a sharp-pointed tool for about 3 seconds to reset the Timer before programming. Resetting the Timer will achieve the following:

1	It shows the software version	
2	It resets the TIMER mode back to 2-7 (default setting)	
3	It resets the TIME and DAY of the clock to default value (i.e.: Mo 00:00) and clears all timer events.	

Setting Day and Time

This Timer has a 24-hour clock. Days, Hours and Minutes are individually set by pressing a combination of the CLOCK button and the corresponding DAY/HOUR/MIN button, as follows:

4	DAY: Press and Hold the CLOCK button, then repeatedly press the DAY button until the correct day is displayed.	
5	HOUR: Press and Hold the CLOCK button, then repeatedly press the HOUR button until the correct hour is displayed.	
6	MINUTE: Press and Hold the CLOCK button, then repeatedly press the MINUTE button until the correct minute is displayed.	

Setting Event #1

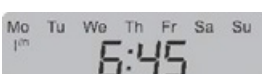
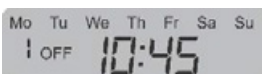

This Timer has a 24-hour clock. Days, Hours and Minutes are individually set by pressing a combination of the CLOCK button and the corresponding DAY/HOUR/MIN button, as follows:

7	Press the TIMER button once, and the timer displays "1 ON" plus a series of - - - - Note: This represents the "Program #1 "ON" time which is about to be saved.	
8	Press the DAY button once, and all the days of the week will appear at the top of the screen, and "0:00" will appear as the time. Press the HOUR button until the LCD screen displays the exact hour required for the system to turn ON. Press the MIN button until the LCD screen displays the exact minute required for the system to turn ON.	
9	Press the TIMER button once again, and the timer displays "1" and "OFF" plus a series of - - - - This represents the "Program #1 "OFF" time which is about to be saved. Repeat step 2 above to set your required OFF time.	

TIMER SETTING

Setting Event #2

Note: If you do not want to use timer 2, then leave both ON and OFF at 00:00.

10	Press the TIMER button once again, and the timer displays "2 ON" plus a series of - - : - - . Note: This represents the "Program #2 "ON" time which is about to be saved.	
11	Follow steps 11 and 12 to set your required "ON" and "OFF" times.	
12	Press the CLOCK button, and your settings are saved, and the real-time is displayed.	
13	Press the MANUAL button until the solid line on the lower part of the LCD is above the AUTO label on the timer front. Your TIMER is now set.	

MANUAL ON / TIMER AUTO / OFF MODE

This setting is displayed above the MANUAL button and can be changed by pressing the MANUAL button. The bar on the LCD moves as follows:

AUTO → OFF → AUTO → ON → AUTO → OFF.

This sequence can start from anywhere.



ON-MODE: The Timer is always ON. The user must press the MANUAL button to turn the Timer OFF or take it to AUTO mode. The LCD screen will not switch off when the Timer switches off at the set time.

OFF-MODE: The Timer is always OFF. The Timer will not switch on at the next set time. The user has to manually press the MANUAL button to take the Timer to AUTO or ON mode.

AUTO-MODE: The Timer will switch ON and OFF on the set time frames. Outside the set timeframe, the Timer is OFF but in AUTO mode.

Display OFF

If the screen stays idle for 30 seconds during TIMER adjustment, it goes to default screen. If the TIMER remains idle for 60 seconds in default screen, the display will switch OFF. This only happens when the main power to the TIMER is off, and the TIMER is being powered by the internal battery.



REPLACING THE BATTERY

NOTE TO ELECTRICIAN: The power supply requires tools to open and access the timer battery case. The battery is a 3V Lithium CR2032 battery. The battery life is expected to be over 5 years and the timer will work, even with a flat battery, provided there is mains power to the timer.

WARNING: KEEP REPLACED BATTERY OUT OF REACH OF CHILDREN. Swallowing can lead to chemical burns, perforation of soft tissue, and death. Severe burns can occur within 2 hours of ingestion. Seek medical attention immediately.

CAUTION: THERE IS A RISK OF EXPLOSION IF BATTERY IS REPLACED BY AN INCORRECT TYPE. DISPOSE OF USED BATTERIES ACCORDING TO THE INSTRUCTIONS ON REPLACEMENT BATTERY PACK

Operating Instructions

CELL OUTPUT CONTROL

The Cell Output Control Dial regulates the amount of sanitation production relevant to the position it has been set to. By adjusting the Cell Output Control Dial clockwise, you increase sanitation production and by turning anticlockwise you reduce production.

To ensure your system is working correctly, follow the steps below:

1	Ensure the Cell Output Control Dial is at maximum (99).
2	With the system running take a sample of water from the skimmer box and conduct a water test, note the result.
3	Take a sample of water from directly in front of the return to pool outlet and conduct a water test, note the result.
4	If the latter is higher in chlorine than the first test, your system is efficiently producing (if not please see troubleshooting).

CELL OUTPUT DISPLAY

Your Control Unit is fitted with digital display. During operation of your Cell, the Output Display Value will illuminate relevant to the percentage at which the Cell Output Control Dial has been adjusted. You can increase or decrease cell output to suit your pool's requirements. As you increase the cell output (by turning the Cell Output Control Dial clockwise), the displayed value will indicate the Amps percentage reading to the Cell increase. You have full control of chlorine production merely by adjusting the Cell Output Control Dial to satisfy your chlorine demand.

Your Control Unit also has on board diagnostics to indicate any issues with the system (see table below for definitions).

CODE	DEFINITION	CODE	DEFINITION
0-99	Cell output production % (Range 0% to 99%).	Pb	(Flashing) there is insufficient water flow through the Cell to produce, if this persists, please refer to troubleshooting.
00	Cell output production is off.	SC	Internal Electrical Problem (see troubleshooting)
99	Cell output production is a maximum.	CE	Cell Error (see troubleshooting)
dg	Automatic cleaning cycle beginning, the self-cleaning function is beginning, this is only displayed for a short period.	OC	Cell Connection (see troubleshooting)
OL	(Flashing) overload condition (see troubleshooting).		

Recommended Water Balance

Regular water testing must be performed to ensure the water chemistry is within the following recommend ranges. Unbalanced water will reduce system efficiency and lifespan. the system uses a combination of Electrolysis and Ozone to sanitise and purify water.

	B-MINERAL MODELS	B-FRESH MODEL
PARAMETER	IDEAL RANGE	IDEAL RANGE
TDS	3,500 – 5,000 ppm	1,200 – 3,500 ppm
Free Chlorine	1.0 - 4.0 ppm	1.0 - 4.0 ppm
Combined Chlorine	Below 0.5 ppm	Below 0.5 ppm
pH	7.4 – 7.6	7.4 – 7.6
Cyanuric Acid	30 – 60 ppm	30 – 60 ppm
Total Alkalinity	80 - 120 ppm	80 - 120 ppm
Calcium	200 - 300 ppm	150 - 250 ppm
Metals	0 ppm	0 ppm
Phosphates	Below 200 ppb	Below 200 ppb

Maintenance

CONTROL UNIT

Ozone Air Filter Media Replacement



Every 6 months or as required

Replace the Ozone Air Filter Media located under the Control Unit, to remove the filter turn it anticlockwise, remove the old cotton wool and replace with half a standard cotton wool ball, only hand tighten the filter when refitting.

PART/ITEM	PART	REPLACEMENT SCHEDULE
Ozone Air Filter Media	Half a Standard Cotton Wool Ball	Every 6 months or as required

WATER BALANCE

Every month or as required

Regular water testing must be performed to ensure the water chemistry is within the recommended ranges. See Recommended Water Balance table.

CELL CLEANING

Every 6 months or as required

Although you have a reverse cycle automatic cell cleaning system, it is recommended from time to time that the Cell be checked for any accumulation of calcium or other deposits that may have built up. We recommend cleaning the Cell twice a year subject to your pool's application and location.

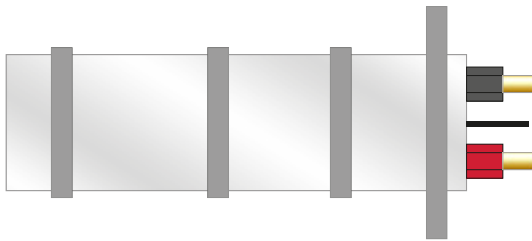

CELL REPLACEMENT

Every 3 years or as required

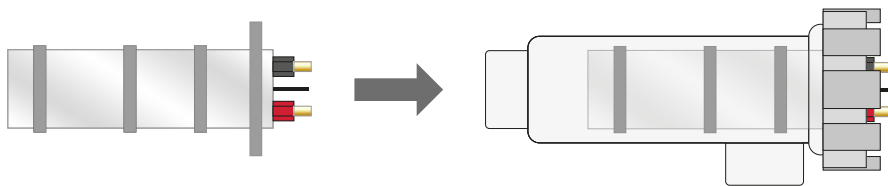

Cell efficiency reduces over time. It is recommended to change the Cell to maintain effectiveness.

PART/ITEM	PART NUMBER	REPLACEMENT SCHEDULE
Cell	Refer to Page 22	Every 3 years or as required

OZONE INJECTION MANIFOLD

Teflon Check Valve Replacement



Every 12 months or as required

The Check Valve in the ozone output line prevents water from returning to the Control Unit. To replace the Check Valve simply pull the white Ozone Teflon Tubing off the Check Valve at both ends and replace with new Check Valve. Make sure that you date the new Check Valve and update the Maintenance Logbook below.

PART/ITEM	PART NUMBER	REPLACEMENT SCHEDULE
Teflon Check Valve	B-TCHK-VLV	Every 12 months or as required

CONTROL UNIT

Internal Manifold Check Valve Set Replacement

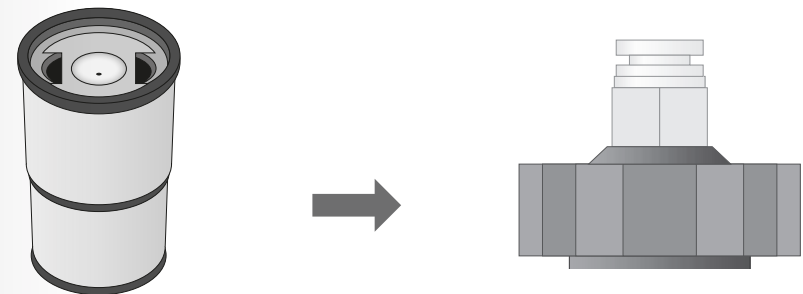

Every 3 years or as required

PART/ITEM	PART NUMBER	REPLACEMENT SCHEDULE
Manifold Check Valve Set	B-MCHK-VLV	Every 3 years or as required

Maintenance Logbook

MONTH	WATER TEST	OZONE AIR FILTER MEDIA	TEFLON CHECK VALUE	MANIFOLD CHECK VALVE SET	CELL
Recommended	Monthly	6 Monthly	Yearly	3 Years	3 Years

1					
2					
3					
4					
5					
6					
7					
8					
9					
10					
11					
12					

1					
2					
3					
4					
5					
6					
7					
8					
9					
10					
11					
12					

Maintenance Logbook (continued)

MONTH	WATER TEST	OZONE AIR FILTER MEDIA	TEFLON CHECK VALUE	MANIFOLD CHECK VALVE SET	CELL
Recommended	Monthly	6 Monthly	Yearly	3 Years	3 Years

1					
2					
3					
4					
5					
6					
7					
8					
9					
10					
11					
12					

1					
2					
3					
4					
5					
6					
7					
8					
9					
10					
11					
12					

Warranty Information

Ozone 1 Pty Ltd, trading as Brauer Swim ("Brauer Swim") guarantees the system to be free from defects in material and workmanship when subjected to normal use and service.

Brauer Swim systems warranty table is as below:

ITEM/PART	PART NUMBER	WARRANTY PERIOD	IN-FIELD PERIOD
Control Unit (excluding Internal Ozone Corona Discharge Unit)	B-OZ-PCB	3 years	1 year
Internal Ozone Corona Discharge Unit (see diagram below for warranty details)	B0211	3-10 years	1 year
Ozone Injection Manifold (excluding Manifold Check Valve Set (Internal))	B0222	3 years	1 year
Manifold Check Valve Set (Internal)	B-MCHK-VLV	1 years	n/a
Cell Assembly (excluding Cell)	B0179-SET	3 years	1 year
Cell - BM50	BM50CELL	3 years prorata	n/a
Cell - BM90	BM90CELL	3 years prorata	n/a
Cell - BM150	BM150CELL	3 years prorata	n/a
Cell - BF70	BF70CELL	3 years prorata	n/a
Ozone Teflon Tubing (excluding Teflon Check Valves)	B0223	3 years	n/a
Teflon Check Valve	B-TCHK-VLV	6 months	n/a
Ozone Air Filter Media	B0220	6 months	n/a

Domestic use only. Commercial use warranty period is a maximum of 1 year for all Items/Parts.

Warranty Information (continued)

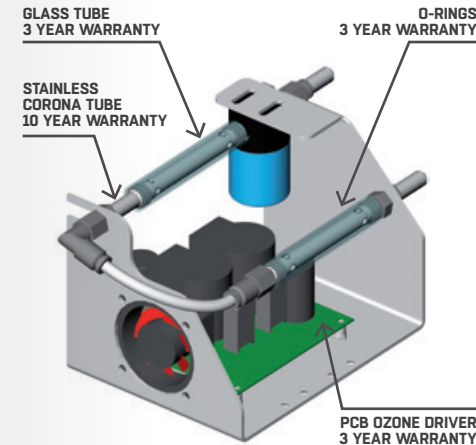

- There are no expressed or implied warranties which extend beyond the face hereof, and Brauer Swim is not liable for any incidental or consequential damages arising from the use or misuse of this product.
- This limited warranty does not apply to any injury, loss, damage, defect or malfunction of the product or failure to function resulting from any failure to operate the product in accordance with the directions contained in the operating instructions, failure to function resulting from any accidents, acts of God, tampering, abuse, acts, omissions, or negligence by anyone other than Brauer Swim, including but not limited to such damage or injuries resulting from improper installation.
- Damage from excessive concentration of one or more chemicals is not covered by this warranty.
- The product is specifically designed for use with swimming pool water, the water must be chemically balanced in accordance with the operating instructions. Operating the product at the incorrect TDS level will shorten the Cell life and void warranty. See recommended Water Balance above ie. B-Mineral models TDS is 3500-4500ppm and B Fresh model TDS is 1200-3500ppm.
- This limited warranty shall apply only to the Customer as an original purchaser and is not transferable.
- Any claim made in relation to this warranty is limited to the cost of replacement or repair of the product or parts claimed to be defective.
- Product must be installed, maintained and operated in accordance with Brauer Swim's specifications and recommendations.
- It is the customer's responsibility to follow safety regulations and laws regarding electrical installation.
- Shipping damage is not covered by this warranty.
- No claims will be recognised without the proof of purchase.
- This warranty becomes invalid if unauthorised person or persons attempt modifications or repairs.
- Any dispute between customer and Brauer Swim must be conducted in Queensland, Australia.

Warranty Registration

Please complete the Warranty Registration Form as soon as possible by scanning the following QR Code or click on the following:

Warranty Registration Link: <https://brauerswim.com/warranty-registration-form/>



See Model & Serial Number Information on last page of this Instruction Manual.

Troubleshooting

FAULT	POTENTIAL CAUSES	ACTION REQUIRED
Cell Output Display "Pb" (no water flow)	<ul style="list-style-type: none"> Pump turned off or disconnected Valves closed Gas sense wire at Cell disconnected Calibration Required 	<ul style="list-style-type: none"> Ensure pump is on Ensure correct valves are open Reconnect sense wire at Cell Ensure Cell is full of water
No display	<ul style="list-style-type: none"> No mains power Control Unit plug removed from power point Control Unit circuit breaker Control Unit is turned off 	<ul style="list-style-type: none"> Ensure there is mains power available Ensure Control Unit is plugged into power point and it's turned on Reset circuit breaker by pushing in Ensure manual mode and sanitation are switched on Contact support at support@brauerindustries.com
Low/No chlorine	<ul style="list-style-type: none"> Insufficient run times Incorrect Cell production setting Low/high mineral/salt levels Loose connections at the Cell (red and black) 	<ul style="list-style-type: none"> Adjust run times to allow more production Increase cell production Check/adjust mineral/salt levels to be within required range Disconnect Cell Leads, then reconnect Cell Leads firmly
Cell Output Display Solid "OL"	<ul style="list-style-type: none"> Possible short circuit in Cell (debris) Extremely high mineral/salt levels 	<ul style="list-style-type: none"> Remove Cell and check for any debris and clean Check and adjust mineral/salt levels

Troubleshooting (continued)

FAULT	POTENTIAL CAUSES	ACTION REQUIRED
No light from Ozone Indicator Light	<ul style="list-style-type: none"> No power to Control Unit Defective Internal Ozone Corona Discharge Unit 	<ul style="list-style-type: none"> Ensure Control Unit has power and is working Contact your Brauer Swim Certified Partner
No bubbles from injector or no evidence of bubbles in pool	<ul style="list-style-type: none"> Excessive back pressure Leak in fitting Filter not working 	<ul style="list-style-type: none"> Check for kinks or clogs in hose or plumbing Check filter Check Ozone Injection Manifold
Water in Control Unit	<ul style="list-style-type: none"> Teflon Check Valve failure Manifold Check Valve Set failure 	<ul style="list-style-type: none"> Verify Teflon Check Valve in Ozone Teflon Tubing is operating properly Verify Manifold Check Valve Set in Ozone Injection Manifold is operating properly
Cloudy water	<ul style="list-style-type: none"> Water chemistry out of balance Total dissolved solids (TDS) level is too high Filter not working 	<ul style="list-style-type: none"> Refer to recommend water balance section Check readings and balance accordingly Clean or replace filter
Display OC (Cell Connection)	<ul style="list-style-type: none"> Cell disconnected Cell lead broken 	<ul style="list-style-type: none"> Check connections in cell and shape of cable
Display CE (Cell Error)	<ul style="list-style-type: none"> Low salt in pool Cell needs replacing Cell with calcium built-up 	<ul style="list-style-type: none"> Add/Adjust salt if required Clean cell with acid Replace cell
Display SC (Internal Error)	<ul style="list-style-type: none"> Internal electrical problem 	<ul style="list-style-type: none"> Turn off unit Call for service or Contact support@brauerindustries.com

Product Support



Product support can be obtained by scanning the following QR Code or use the following website link:

Product Support Link:

<https://brauerswim.com/product-support-contact-form/>

Product Specifications



MODEL	MAX POOL VOLUME	DIMENSIONS CONTROL UNIT (W x H x D)	WEIGHT	ENCLOSURE	MAX CURRENT	TEMP OPERATION RANGE
	LITRES	CM	KG	IP	AMP	C
70	70,000	28 x 50 x 28	25	23	10	-20-40



MODEL	MAX POOL VOLUME	DIMENSIONS CONTROL UNIT (W x H x D)	WEIGHT	ENCLOSURE	MAX CURRENT	TEMP OPERATION RANGE
	LITRES	CM	KG	IP	AMP	C
50	50,000	28 x 50 x 28	20	23	10	-20-40
90	90,000	28 x 50 x 28	22	23	10	-20-40
150	150,000	28 x 50 x 28	25	23	10	-20-40

Max Pool Volume assumes that the pool is Residential Use Only, B-Mineral models TDS 3,500 – 4,500ppm, B-Fresh model TDS 1,200 – 3,500ppm, pH 7.2-7.6, temperature is a maximum of 28 degrees, average depth of more than 1.2m and turnover rate of 4 hours or less. Does not take into consideration bather type, pool surface, automated dosing, secondary sanitation method, water temperature, slides, fountains, waterfalls etc. Brauer is not liable for model selection based on reference to Max Pool Volume.

Contact Us

Brauer Swim
Unit 3, 89 Spencer Rd
Nerang QLD 4211
AUSTRALIA

Tel 1300 696 631
Email Info@brauerindustries.com
Web www.brauerswim.com
ABN 99 109 648 722

Model & Serial Number information

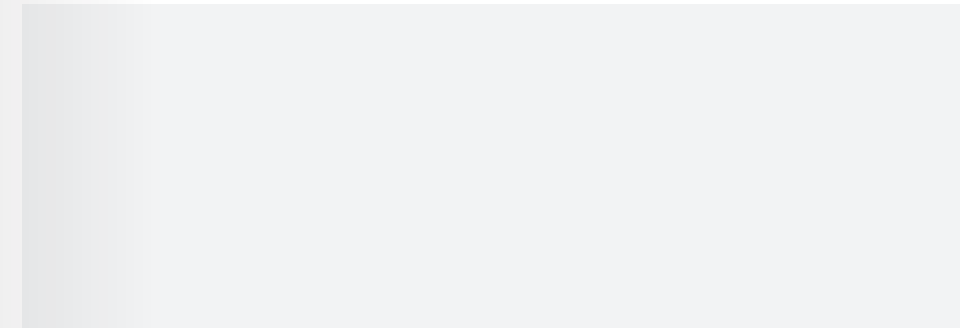

Copyright Notice: Copyright 2024 by Ozone 1 Pty Ltd, trading as Brauer Swim. All rights reserved. No parts of this publication may be reproduced, transmitted or stored in a retrieval system in any form or by any means, electronic, mechanical, photocopying, recording, or otherwise, without the prior written permission of Ozone 1 Pty Ltd.

Trademarks: Throughout this document trademark names may have been used. Rather than placing a trademark symbol in every occurrence of a trademark name, we state that we are using the names only in an editorial fashion and to the benefit of the trademark owner with no intention of infringement of the trademark.

Notice of Liability: While every effort has been taken to ensure the accuracy of this document, neither Ozone1 Pty Ltd nor any of its official representatives shall have any liability to any person or entity with respect to any liability, loss or damage caused or alleged to be caused directly or indirectly by the information contained in this guide. Should you find any error or inconsistency, please notify us accordingly. Ozone1 Pty Ltd reserves the right to make changes to features and specifications at any time without prior notification in the interest of ongoing development and improvement.



BRAUER
SWIM

Get in touch today...

AUS 1300 696 631 | NZ 0800 112 530 | brauerswim.com |  /brauerswim/

Designed and Manufactured in Australia Since 1998.

