



B-Balanced 150

INSTRUCTION MANUAL

pH Controller



Instruments by Brauer Swim

www.brauerswim.com | support@brauerswim.com | 1300 696 631



TABLE OF CONTENTS

1. SAFETY	3
2. GENERAL OVERVIEW	3
3. SPECIFICATIONS	4
4. MAINTENANCE	5
4.1 Injection Point on Injector Valve	5
4.2 Lubricate Squeeze Tube	5
4.3 Replace Squeeze Tube	5
5. HELPFUL HINTS	5
6. CONTENTS	5
7. TOOLS NEEDED	6
8. POOL PREPARATION	6
9. INSTALLING THE pH CONTROLLER	6
10. NAVIGATING THE LCD pH MENUS ON YOUR B-Balanced	8
10.1 Accessing the B-Balanced Start-up Settings.....	8
10.2 pH Run Time – How the dosing system works	10
10.3 pH Demand or Prime – Add acid manually or prime clear flexible PVC tubes.....	11
10.4 Brightness Setting.....	12
10.5 Clock Setting	12
10.6 Contrast Setting.....	13
10.7 Pool Size	13
10.8 Sanitiser Setting.....	14
10.9 Winter Mode	15
10.9.1 Turning off Winter Mode.....	16
11. pH CONTROLLER TROUBLESHOOTING	17
12. SPARE PART NUMBERS	18
13. WARRANTY	19
14. DISCLAIMER	19

1. SAFETY

Important Warnings: This manual contains important information about the installation, operation, and safe use of this product. This information should be given to the owner and/or operator of this equipment. When installing and using this electrical equipment, basic safety precautions should always be followed. Failure to follow safety warnings and instructions in this manual can result in serious injury and/or damage to your equipment. Read and follow all warning notices and instructions which are included in this manual.

- The pH controller case contains live components internally. There is a danger of electric shock if opened. If the power cord is damaged then it should be replaced by the manufacturer, their agent or similar qualified person, to avoid a hazard.
- The product shall be installed by a qualified person in accordance with AS/NZS 3000 wiring rules.
- The pH controller should be installed in the correct pool zone and connected to supply via a power outlet that is protected by a residual current device (RCD) having a rated residual operating current not exceeding 30mA. The power outlet should have a degree of protection suitable for the pool zone.
- To reduce the risk of injury, do not permit people with lack of experience and knowledge, to use this appliance unless they have been given supervision or instruction concerning use of the appliance.
- To reduce the risk of accidents or incidents, service on the unit should only be performed by a qualified pool service professional, after disconnecting it from the mains power supply.
- During the installation check the following:
 - that the injector point pressure is lower than 150kPa (to ensure optimum flow);
 - that the peristaltic pump's acrylic front cover is correctly fitted;
 - that the suction tube is securely fitted in the acid container, with weight touching the bottom and the drum label is fitted on the outside of the container;
 - that the suction tube is fitted to the left side and the injector tube to the right;
 - that the injector valve o'ring is fitted between the valve and the CLEAR faucet tee and the BLACK lock nut is securely fastened.

Important Safety Instruction: When mixing acid with water, **ALWAYS ADD ACID TO WATER. NEVER ADD WATER TO ACID.** Always wear the appropriate safety equipment specified by the acid supplier when handling acid.

The system uses a **1 : 3 Acid : Water** mix ratio (e.g. with a 20-litre drum add 15 litres water then 5 litres acid). It is important to use this mix for the correct acid volume to be added.

DO NOT PLUG IN IF CARTON IS WET.

Should you require further information visit www.brauerswim.com



When using the B-Balanced LCD Controller:

- Observe all applicable local, state, and federal safety regulations.
- Take proper precautions with prescribed environmental and operational conditions.
- Consider chemical compatibility with all wetted materials.

2. GENERAL OVERVIEW

Congratulations on your recent purchase of your Brauer Swim B-Balanced Controller. Please take a moment to read through the entire manual before installing your new unit.

Your B-Balanced Controller must be installed and operated as specified.

While every effort has been made to ensure that the information contained in this guide is accurate and complete, no liability can be accepted for any errors or omissions. Brauer Swim reserves the right to change the specifications of the hardware and software described herein at any time without prior notice.

The pH in your swimming pool will slowly rise due to factors such as alkalinity, the addition of fresh water and as sanitiser is produced in a salt/mineral water system. A rise in pH reduces the effectiveness of the sanitiser, so it is important to ensure that the pH remains in the correct range.

The pH of the water can be lowered by the addition of hydrochloric acid – and if your system has the optional pH control, this can be done automatically. Brauer Swim B-Balanced Controller uses an algorithm to calculate how much how much acid needs to be dosed to correct the pH.

Note: While the algorithmic pH control is effective, it does not measure pH. pH testing should be undertaken manually on a weekly basis to ensure the pH is correct.

3. SPECIFICATIONS

SPECIFICATIONS	
Volts & Amps Input (ac)	220-240 V, 0.1 A
Total Power Consumption)	13 W Motor, 20 W Max.
Frequency	50 Hz
Controlled Output	0-1000 ml per hour
Rated Pressure	350 kPa (optimum for injector is 150 kPa)
Squeeze Tube	Tygon® Norprene® (Commercial spec)
Motor Speed	10 RPM
Tubing Size	6m long x 6mm diameter Clear Flexible PVC
Power Cord	Approved piggy-back type
Wall Mounting	Simple Click ON - Clip OFF
Water Connection	CLEAR Acrylic Faucet Tee 50mm pipe
Water Flow Rate (L/min)	80-650 L/min
Ingress Protection Rating	IP35

***NOTE:** Certain specification may change without notice for reasons of improvement or better performance.

4. MAINTENANCE

Whilst this pH Controller is built from the best engineered practices and material, please ensure you regularly undertake the following basic maintenance:

4.1 Injection Point on Injector Valve

Check the injection point periodically, by looking through the CLEAR faucet tee, for build-up of solid matter at the end of the clear flexible PVC tubing. This could only occur from contaminants in your acid container and the result is a blockage hindering the flow of acid and reducing the life of the pump tube and roller block. While unscrewing the BLACK lock nut, take care not to lose the rubber O-ring.

4.2 Lubricate Squeeze Tube

Lubricate the pump squeeze tube every 3-6 months. Use a silicone-based lubricant only as petroleum-based lubricants will cause damage to the tube and rollers.

4.3 Replace Squeeze Tube

Depending on usage, the squeeze tube may need replacement after 1-2 years of use. Before replacing, please ensure that the suction and injection tubes are empty. To change the squeeze tube, please follow the instructions included with the replacement kit. Only use our original sized commercial grade Tygon® Norprene® tube as incorrect sizing will result in early failure of the Tri Roller Block.

5. HELPFUL HINTS

Read and keep your Manual in a safe place.

Test your swimming pool water on a regular basis and take your pool water sample to your local pool professional at least twice a month.

6. CONTENTS

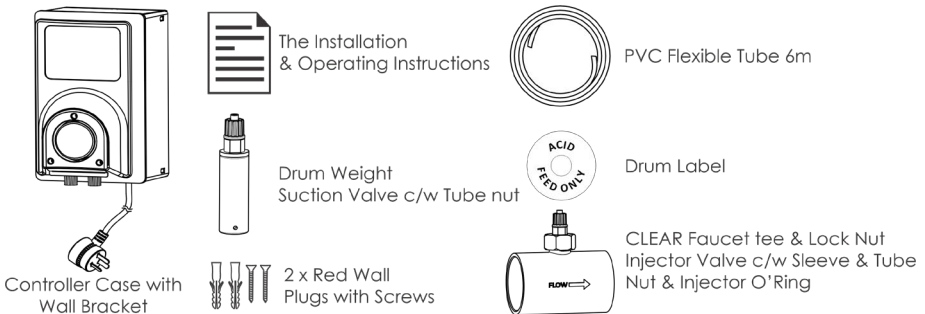

7. TOOLS NEEDED

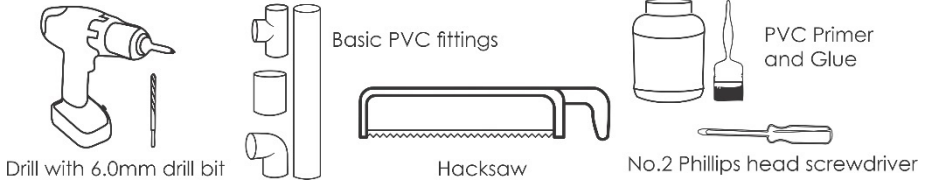

8. POOL PREPARATION

Please ensure that your pH is balanced to the recommended level for your swimming pool surface.

Ideal pH Levels: Concrete Pools: 7.4-7.6

Fibreglass and Vinyl Pools: 7.0-7.2

A pH of 8.0 makes your chlorine only about 26% efficient so that is why it is critical to keep your pH in range. A correct pH level must be maintained to prevent problems such as black spot, staining, cloudy water etc. An incorrect pH level can damage the surface finish and walls of your pool.

When pH is high you can add Hydrochloric Acid to lower the pH. When pH is low you can add sodium bicarbonate (soda ash) to increase the pH.

9. INSTALLING THE B-Balanced CONTROLLER

Installation Diagram

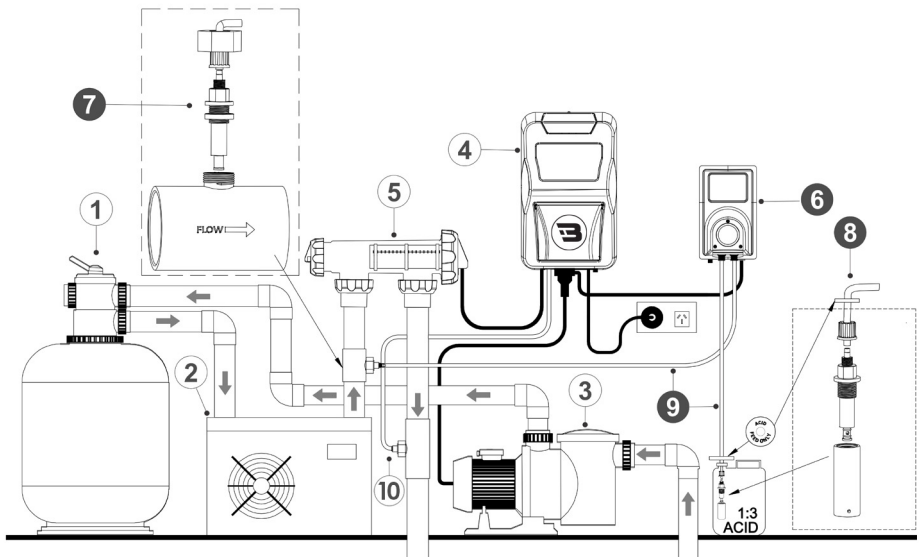

1 ● Pool Filter

2 ● Heat Pump

3 ● Pool Pump

4 ● Pool Sanitiser

5 ● Cell Housing

6 ● pH Controller

7 ● Injection with Tee

8 ● Suction with Drum
Weight & Label

9 ● PVC Flexible Tube 6m

10 ● Ozone Injector Manifold

STEP 1: Remove the contents from the box and carefully plan all steps using the installation diagram, and by reviewing the steps below.

STEP 2: Position the B-Balanced Controller box as indicated in the installation diagram, ensuring it is NOT too close to other equipment or power outlets, but close enough to the power supply so the piggy-back power cord can plug in to its socket outlet.

STEP 3: Attach the B-Balanced Controller to the wall by removing the simple "Click ON – Click OFF" wall mounting bracket that is attached to the controller case. Use the wall plugs and screws provided.

3.1: Click OFF the wall bracket clip

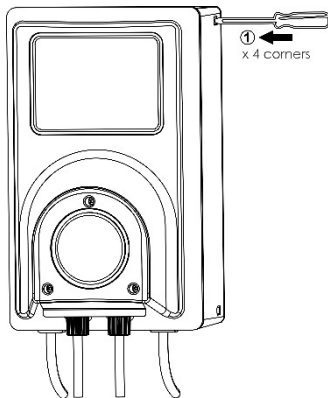

3.2: Pull the wall bracket away from case.

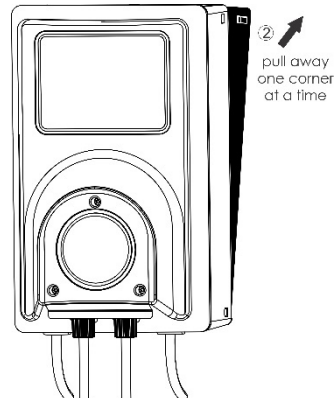

3.3: Mount the bracket to the wall

3.4: CLICK ON the case to the wall bracket

This unique design keeps the controller case unexposed to any possible water entry.

STEP 4: Fit the CLEAR faucet tee c/w injection valve to the pool water line, avoiding high pressure areas (i.e., after the pump, filter, and prior to heat pump). It can be installed prior to the cell housing (or after if needed).

STEP 5: Cut and connect a length of clear flexible PVC tube that will reach from the outlet at the base of the peristaltic pump (right side) to the injection valve, that is mounted in the CLEAR faucet tee, using the tube nut to secure the tube.

STEP 6: Do not cut the other length of clear flexible PVC tube yet. Place the acid drum (with the required mix) in the required position, in a ventilated area, preferably not near this or other pool equipment (at least 2m or more away), as the acid is corrosive and equipment damage will occur.

NOTE: Some states use undiluted hydrochloric acid to feed the B-Balanced Controller (i.e., there is no container with a 1:3 mix). In this case, the operator needs to manually change the run time in Menu 'pH1 Run Time' from the displayed result to approximately $\frac{1}{4}$ of this reading (i.e., if 15min/day is displayed then change this to 4min/day by following the instructions below in section 10.2 pH Run Time – How the dosing system works).

If you are using a low-fuming type of acid, such as 32% sulphuric acid, then you may need to double the run time as its ability to lower the pH is less than that of hydrochloric acid. Once again, you need to test your water weekly until you reach the optimum setting for your system.

The system uses a **1 : 3 Acid : Water** mix ratio (e.g. with a 20-litre drum add 15 litres water then 5 litres acid). It is important to use this mix for the correct acid volume to be added.

Important Safety Instruction: When mixing acid with water, **ALWAYS ADD ACID TO WATER. NEVER ADD WATER TO ACID.** Always wear the appropriate safety equipment specified by the acid supplier when handling acid.

STEP 7: Pass this clear flexible PVC tube through the drum label and a 6.0mm hole in the acid drum vent cap. Connect the clear flexible PVC tube to the suction valve that is mounted to the drum weight, using the tube nut to secure the tube. Before placing the tubing into the drum, measure the tubing against the outside of the drum and measure the feed tubing so that there is sufficient tubing. Lower the drum weight into the acid drum and screw on the drum cap.

STEP 8: Connect the piggy-back power cord to the AC socket outlet of the sanitiser or a wall socket.

STEP 9: Start up your pool pump and check the system for any leaks. Repair any such issues.

STEP 10: Prime the acid feed lines and finalise run settings using the menus below.

10. NAVIGATING THE LCD pH MENUS ON YOUR pH CONTROLLER

As fresh water is added, or chlorine is produced the pool pH will slowly increase. This can be offset by adding small doses of acid to the pool automatically. This B-Balanced Controller uses a maintenance free algorithm that calculates the amount of acid, per dose, that is needed to maintain the pH. Initially it is based on the size of your pool, but through your testing, it can smartly be adjusted to make it truly near-maintenance free for you the owner.

NOTE: *It is important that the system is initially adjusted based on pH result to suit your pool and that pool pH is still checked regularly.*

10.1 Accessing the B-Balanced Start-up Settings

To commence using your B-Balanced Controller you will be required to follow these initial start-up procedures.

PROCEDURE On initial start up the B-Balanced Controller will progress through the Start-up Settings, commencing with Start-up Clock Set.

LCD DISPLAY

```
START UP CLOCK SET  
ACTUAL TIME: HH:MM  
[^] or [v] to change  
[ENTER]SAVE
```

PROCEDURE Press [v] or [^] to adjust the hour and [ENTER] to save the selection. Repeat this process for minutes and press [ENTER] save the selection. [<] BACK takes you back to the previous screen if any changes are required.

LCD DISPLAY

```
START UP CLOCK SET  
ACTUAL TIME: HH:MM  
[^] or [v] to change  
[ENTER]SAVE
```

```
START UP CLOCK SET  
ACTUAL TIME: HH:MM  
[^] or [v] to change  
[ENTER]SAVE [<] BACK
```

PROCEDURE The following screen, Start-up Information, will display immediately after the Start-up Clock Set, allowing you to set the volume, of your swimming pool. Increments or decreases can be made in 1000 litre amounts by a single press, if you press these buttons for 10 seconds this will change values more rapidly by a rate of 10,000 litres. Once you have the correct volume, press [ENTER] to save.

LCD DISPLAY

```
START UP INFORMATION  
POOL SIZE: XX XXX Lt  
[^] or [v] to change  
[ENTER]SAVE [<] BACK
```

PROCEDURE The unit is now set and will show the following display. This is the 'Default Display Screen'.

LCD DISPLAY

HH:MM	FW X.X
MODE: AUTO	pH: OFF
ON TIME: XXXX min/day	
[ENTER] MENU	

10.2 pH Run Time – How the dosing system works.

The default setting on the B-Balanced is for the acid dosing system to be ON. This 'pH1 Run Time' is programmed automatically when setting up the volume/size of the swimming pool in the controller. The system calculates how many minutes per day your B-Balanced Controller should run based on the volume of your pool, and this can be manually changed.

PROCEDURE To adjust the run time or turn OFF the acid dosing of the B-Balanced Controller, enter the 'pH1 Run Time' menu from the Main menu, by pressing the [ENTER] button, and then, press [ENTER] again to select 1. pH Run Time (Auto). The LCD will now show 'On Time: ---- min/day'. Press [^] or [v] to adjust the ON Time in min/day. Pressing [ENTER] saves the required run time and returns to you to the main menu. Saving this Run Time will result in the time being saved as the new default running time of the unit. Entering 0 min/day means the system will not run at all.

Once set the unit will return to the 'Default Display Screen'.

LCD DISPLAY

<ol style="list-style-type: none"> 1. pH Run Time (Auto) 2. pH Demand/Prime 3. Brightness [^]UP [v]DN	pH RUN TIME (Auto) ON Time: ---- min/day [^] or [v] to change [ENTER] SAVE [←] BACK
--	--

PREVIOUS NOTE: Some states use undiluted hydrochloric acid to feed the B-Balanced Controller (i.e., there is no container with a 1:3 mix). In this case, the operator needs to manually change the run time in Menu 'pH1 Run Time' from the displayed result to approximately ¼ of this reading (i.e., if 15min/day is displayed then change this to 4min/day by following the instruction above).

If you are using a low-fuming type of acid, such as 32% sulphuric acid, then you may need to double the run time as its ability to lower the pH is less than that of hydrochloric acid. Once again, you need to test your water weekly until you reach the optimum setting for your system.

10.3 pH Demand or Prime – Add acid manually or prime clear flexible PVC tubes

The 'pH2 DEMAND or PRIME' quantity can be manually adjusted from 0 - 5000 ml. The default reading is always 100 ml. This function is useful for:

- Priming tubes after an acid drum change.
- Adding the required acid from your acid demand test.



IMPORTANT: Enter the exact amount from your test result in ml (e.g. 500ml) and the system automatically adds 4 times that amount, thereby allowing for the 1:3 ACID: WATER mix ratio in the acid drum.

<p>PROCEDURE</p>	<p>Select Menu 2 pH Demand/Prime from the Main menu. The LCD will now show 'Acid Demand: XXX ml'. Press [+] or [-] to adjust the quantity of acid required in millilitres (ml). If you press the key for 10 seconds volume will increase or decrease by 10ml, Pressing [ENTER] saves the required quantity, the peristaltic pump starts turning and the ml reading starts counting down. You can adjust the quantity in this menu if you wish or you can press [<] and return to the chlorinator default display screen. If the lines are primed, you can stop the peristaltic pump by entering a reading of '0 ml'. Once dosing is finished the unit will revert to the DDS.</p>	
<p>LCD DISPLAY</p>	<pre> 1. pH Run Time (Auto) 2. pH Demand/Prime 3. Brightness [^] UP [V] DN </pre>	<pre> pH DEMAND OR PRIME Acid Demand: XXX ml [^] or [V] to change [ENTER] SAVE [<] BACK </pre>
	<pre> pH DOSE TIME LEFT Time Left: xxx min [V] to lower Time [ENTER] SAVE [<] BACK </pre>	<pre> HH:MM FW X.X MODE: AUTO pH: OFF ON TIME: XXXX min/day [ENTER] MENU </pre>

10.4 Brightness Setting

If you need to change the brightness of the LCD display, you can do so by using this menu.

PROCEDURE	To change the brightness, use the [v] button to scroll to the brightness menu and press [ENTER]. Use the [v] or [^] button to select the new setting and press [ENTER] to save. Once the brightness is updated, the unit will revert to the MENU.	
LCD DISPLAY	<pre>1. pH Run Time (Auto) 2. pH Demand/Prime 3. Brightness [ENTER] ENTER [<] BACK</pre>	<pre>BRIGHTNESS DEFAULT Setting: xxx% [^] or [v] to change [ENTER]SAVE [<]BACK</pre>

10.5 Clock Setting

If you need to change the actual time on your B-Balanced Controller, you can do so in this menu.

PROCEDURE	To enter 'Clock Setting' to update the actual time use the [v], [^] & [ENTER] button to enter menu 4 and as per the instructions in the unit set up section set the new time for the clock. Once you have finished setting the time, the unit will revert to the DDS.	
LCD DISPLAY	<pre>4. Clock Settings 5. Contrast 6. Pool Size [ENTER] ENTER [<] BACK</pre>	
	<pre>4. Clock Settings ACTUAL TIME: HH:MM [^] or [v] to change [ENTER]SAVE [<] BACK</pre>	<pre>4. Clock Settings ACTUAL TIME: HH:MM [^] or [v] to change [ENTER]SAVE [<] BACK</pre>

10.6 Contrast Setting

If you need to change the contrast setting of the LCD display, you can do so by using this menu.

PROCEDURE	To change the contrast, use the [v] button to scroll to the contrast menu and press [ENTER]. Use the [v] or [^] button to select the new setting and press [ENTER] to save. Once saved the unit will revert to the DDS.	
LCD DISPLAY	<pre>4. Clock Settings 5. Contrast 6. Pool Size [ENTER] ENTER [<] BACK</pre>	<pre>CONTRAST DEFAULT Settings: xxx% [^] or [v] to change [ENTER]SAVE [<] BACK</pre>

10.7 Pool Size

If you need to revise your swimming pool size, you can do so in this menu.

PROCEDURE	To enter a new pool volume, enter the 'Pool Size' menu from the Main menu using the [^], [v] & [ENTER] button
LCD DISPLAY	<pre>4. Clock Settings 5. Contrast 6. Pool Size [ENTER]SAVE</pre>

10.7 Pool Size (cont.)

PROCEDURE	The volume will flash to show it can be changed. To enter the updated pool size press [^] or [v] to change it in 1,000 Lt increments but if either [^] or [v] buttons are held for 5 seconds, the increments or decrease will be in 5,000 Lt. rate; and if either [^] or [v] buttons are hold for 30 seconds, the increments or decrement will be in 10,000 Lt. rate. Press [ENTER] to save your pool size. The unit will then revert back to the DDS.
LCD DISPLAY	<div style="border: 1px solid black; padding: 5px; text-align: center;"><p>NOTE: Litres not m³</p><p>POOL SIZE: XXXX,000Lt</p><p>[^] or [v] to change</p><p>[ENTER]SAVE [<]BACK</p></div>

10.8 Sanitiser Setting

Here, you can adjust the default Sanitiser Output Setting which is automatically set to 100%. If you chose to reduce the output of your sanitiser you can update the output setting in the B-Balanced to reflect the change in sanitiser output.

PROCEDURE	To change the Sanitiser/Oxidiser Setting, enter the 'Sanitiser Setting' menu from the Main menu using the [^], [v] & [ENTER] button
LCD DISPLAY	<div style="border: 1px solid black; padding: 5px; text-align: center;"><p>7. Sanitiser Settings</p><p>8. Winter Mode</p><p>[ENTER]SAVE</p></div>

10.8 Sanitiser Setting (cont.)

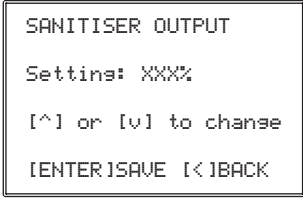
PROCEDURE	The setting 50% is displayed and will flash to show it can be changed. To enter the updated output [^] or [v]. Press [ENTER] to save your sanitiser setting and go to the default display. (<) BACK allows you to exit the menu if you do not need to update the setting.
LCD DISPLAY	 <pre>SANITISER OUTPUT Settings: XXX% [^] or [v] to change [ENTER]SAVE [<]BACK</pre>

10.9 Winter Mode

During the winter months when water temperature drops, and evaporation decreases, your pool will require less acid to control the pH. This feature allows you to winterise your pool and decrease the output of the B-Balanced to 50% by default. You can decrease or increase this manually if you wish to by manually changing the setting from 0 to 90%.

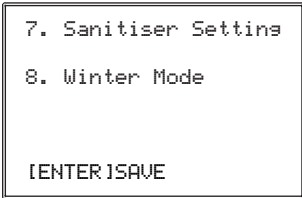
PROCEDURE	To change the setting to 'Winter Mode', enter the Main menu using the [^], [v] & [ENTER]
LCD DISPLAY	 <pre>7. Sanitiser Settings 8. Winter Mode [ENTER]SAVE</pre>

10.9 Winter Mode (cont.)

PROCEDURE	The setting 100% is displayed and will flash to show it can be changed. To enter the updated output [^] or [v]. Press [ENTER] to save your pool size and go to the default display. (<) BACK allows you to exit the menu if you do not need to update the setting.
LCD DISPLAY	<pre>WINTER MODE OUTPUT Settings: XX% [^] or [v] to change [ENTER]SAVE [<]BACK</pre>

10.9.1 Turning off Winter Mode

As temperature once again increases and your swimming pool requires more chlorine and additional water, due to evaporation, it will be necessary to turn off winter mode, you can use the directions below to do so.

PROCEDURE	Enter the 'Winter Mode' setting in the main menu. The current winter setting is displayed and will flash to show it can be changed. To exit "Winter Mode" press [ENTER] to save . To turn off 'Winter Mode' or stay in Winter mode, press [^] to exit, or [v] to continue in the same output. (<) BACK allows you to exit the menu if you do not need to update the setting.				
LCD DISPLAY	<table border="0"><tr><td><pre>7. Sanitiser Settings 8. Winter Mode [ENTER]SAVE [<]BACK</pre></td><td><pre>WINTER MODE OUTPUT Settings: XX% [^] or [v] [ENTER]SAVE [<]BACK</pre></td></tr><tr><td><pre>The Current WINTER MODE OUTPUT Settings is: 50%</pre></td><td><pre>Do you want to exit Winter Mode? [^] YES [v] NO</pre></td></tr></table>	<pre>7. Sanitiser Settings 8. Winter Mode [ENTER]SAVE [<]BACK</pre>	<pre>WINTER MODE OUTPUT Settings: XX% [^] or [v] [ENTER]SAVE [<]BACK</pre>	<pre>The Current WINTER MODE OUTPUT Settings is: 50%</pre>	<pre>Do you want to exit Winter Mode? [^] YES [v] NO</pre>
<pre>7. Sanitiser Settings 8. Winter Mode [ENTER]SAVE [<]BACK</pre>	<pre>WINTER MODE OUTPUT Settings: XX% [^] or [v] [ENTER]SAVE [<]BACK</pre>				
<pre>The Current WINTER MODE OUTPUT Settings is: 50%</pre>	<pre>Do you want to exit Winter Mode? [^] YES [v] NO</pre>				

11. B-Balanced CONTROLLER TROUBLESHOOTING

	Fault Indication	Potential Cause	Remedy
11.1	pH controller is not turning on.	pH controller not set correctly. pH controller power cord not plugged in. Settings are correct but peristaltic pump is not turning.	See Manual Section 10. Check that power cord is plugged in the wall outlet. Contact your service agent.
11.2	Everything displays correctly but pH level is not changing when testing pool water.	Acid drum is low or empty.	Check acid level and replenish if necessary.
11.3	pH controller is not running when sanitiser is ON.	The pH controller has already operated its run cycle for the day.	The pH controller will not run again if it has already completed its automatic cycle. It can run outside of sanitiser times.
11.4	pH controller is running but the pool pump is not ON.	The pH controller can run outside of your pump run times and it will also assist with cleaning the sanitiser cell plates in this case.	The is not a problem.
11.5	pH Controller tri-roller is turning but acid is not pumping.	Air leaks on the squeeze tube, injector tube or suction tube due to potential breaks. Excessive wear on the squeeze tube. Excessive wear on the tri-roller block.	Check the tubes for damage or leaks and repair such or replace tubes. Order a replacement squeeze tube kit and replace the tube. Order a replacement tri-roller block assembly and replace the entire tri-roller block.
11.6	Water flow returning from pool to the acid drum.	In the unlikely event of this happening, it can only be one of two things: i. Worn/damaged injector sleeve; ii. Worn tri-roller block.	Replace the injector sleeve. Replace the tri-roller block.
11.7	pH level in the pool is too high or too low.	Incorrect pH run time. Incorrect ACID:WATER mix. Incorrect ACID DEMAND amount entered.	Adjust pH run time to suit as per procedure in 10. The system uses a 1:3 mix ration. Ensure you have this required mix. You should only enter the required acid, not thew mix. So, if you need 500ml only enter this. The system allows for the 1:3 mix.

12. SPARE PART NUMBERS

BRAUER B-BALANCED pH SCHEMATIC

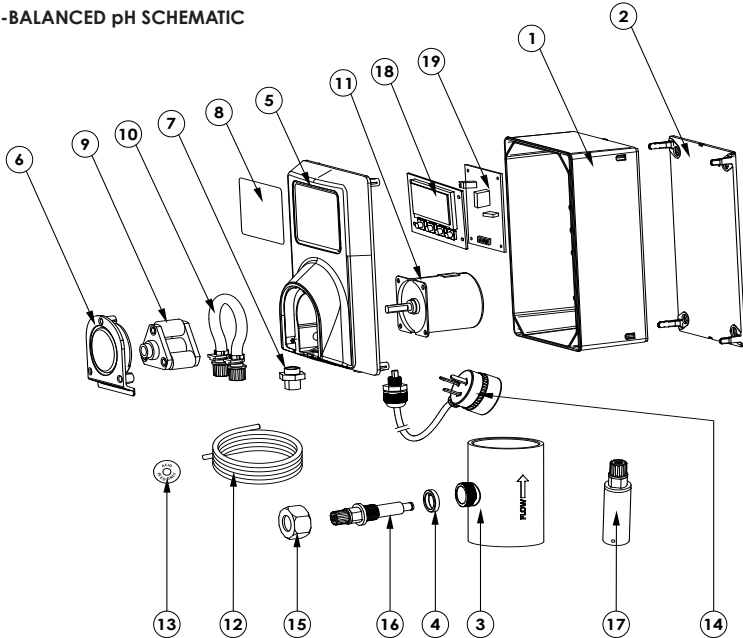

PART NO	CODE	QTY	DESCRIPTION
1	N00302	1	pH Base Body
2	N00306	1	pH Wall Bracket
3	N01185	1	pH Faucet Tee 50mmx3/4" CLEAR
4	N01186	1	O'Ring - Seal to suit pH Injector Valve
5	N01339	1	Case Front Cover - LCD pH Controller
6	N01340	1	Acrylic Cover - pH Controller CLEAR
7	N01078	1	pH LCD Programming Cable
8	N01510	1	Front Sticker - BRAUER pH Balanced
9	N01353	1	pH Tri Roller Block (assembled)
10	N01355	1	pH Squeeze Tube Kit c/w Adaptors, Clamps & Lube
11	N01357	1	pH Motor - 240Vac 13W 10rpm
12	N01360	1	pH PVC Flexible Tubing, CLEAR, 6.0mmOD (per m)
13	N01361	1	pH Drum Label
14	N01364	1	Power Cord - pH c/w Piggy Back Socket
15	N01365	1	Lock Nut - pH Injector BLACK
16	N01367	1	pH Non-Return Injector Valve c/w Sleeve & Tube Nut
17	N01368	1	pH Drum Weight Kit - includes Weight, Suction Valve and Tube Nut
18	N01446	1	PCB - pH LCD Main Power PCB
19	N01447	1	PCB - pH LCD Control PCB

13. WARRANTY

This product is warranted for (12) twelve months against defects in workmanship and materials if used for its intended purpose and maintained according to instructions. This warranty is limited to repair or replacement, depending on the problem of the product. If the product is found to have been misused or damaged due to water entry/mechanical damage/accidental damage, this will not be covered under warranty, and, in such cases, no warranty will apply.

What is covered? Repairs/parts/factory labour, or a replacement unit if applicable.

What is not covered? Damage due to accident, misuse, water penetration of the handheld enclosure, tampering, or lack of prescribed maintenance is not covered under this limited warranty.

Should you need to lodge a warranty with the Brauer Swim service department, ensure to include the product serial number, purchase date, and type of failures. If returned to Brauer Swim, ensure proper packaging so that no additional damages occur during transport. The customer is liable to return the B-Balanced to Brauer Swim.

This limited warranty is the sole and complete warranty for Brauer Swim and shall be limited to the cost of the meter. In no event shall Brauer Swim be liable for incidental or consequential damages.

14. DISCLAIMER

Brauer Swim has made every attempt to ensure the accuracy and reliability of the information provided in this manual. However, the information is provided "as is". We shall not be liable for any loss or damage of whatever nature (direct, indirect, consequential, or other), which may arise due to the use of this product.

HANDY QR CODE





Instruments by Brauer Swim

www.brauerswim.com | support@brauerswim.com | 1300 696 631
3/89 Spencer Road, Nerang QLD 4211 Australia



*Designed and
Made in
AUSTRALIA*