



OmniLogic®

Network Troubleshooting Guide



Safety Precautions



High Voltage Electrocution Hazard

The following safety precautions must be adhered to when inserting/removing the USB drive from the MSP.

Hazardous voltage can shock, burn, cause serious injury and or death. To reduce the risk of electrocution and or electric shock hazards:

- Only qualified technicians with relevant State/Federal/Local Government qualifications, should remove the dead front
- Replace damaged wiring immediately as per AS/NZS 3000 Wiring Rules Latest Edition
- Insure panel is properly grounded and bonded

Table of Contents

OmniLogic® Overview & Terminology	Pg. 4-5
OmniLogic: Main PCB Layout (MPP) & MSP Layout	Pg. 6-7
OmniLogic: Wi-Fi Bridge (HLWLAN)	Pg. 8
How To:	Pg. 9-24
Download Firmware	10
Upgrade Firmware	11-12
Directly Connect Via Ethernet	13-14
Connect Via Wi-Fi	15-18
Create a Web Account	19
Register OmniLogic	20-21
Safely Reboot MSP	22
Connect MSP to a Hotspot	23
Verify Web Server Information	24
Troubleshooting:	Pg. 25-50
1. Wired Ethernet: "MSP Not Found"	26-34
2. Wi-Fi Connection: "MSP Not Found"	35-47
3. 24V LED Not Illuminated	48-50

OmniLogic: Overview

- The OmniLogic is an internet and App ready, intuitive, modular automation system.
- This elite automation system features a USB backup and upgrade option. The USB feature allows customers and servicers to back up existing configurations as well as upgrade the system with the latest revision in minutes.
- With touch screen technology the MSP or display allows users to navigate through screens and commands in virtually any lighting condition.
- Each OmniLogic base unit supports up to 10 switch GPO's, 8 valves, 8 heaters, and 8 sensors. It also supports up to 25 themes (groups) and 50 favorites.



OmniLogic: Terminology

Term	Description
MSP	Main System Processor (display)
MPP	Main Panel Processor (main board)
MP	Main Panel (enclosure)
PSU	Power Supply Unit (PWR Supply)
I/O	Input / Output Expansion Card
HVR	High Voltage Relay
LVR	Low Voltage Relay
LVA	Low Voltage Actuator
PRB	Power Relay Board

OmniLogic: Main PCB Layout (MPP)

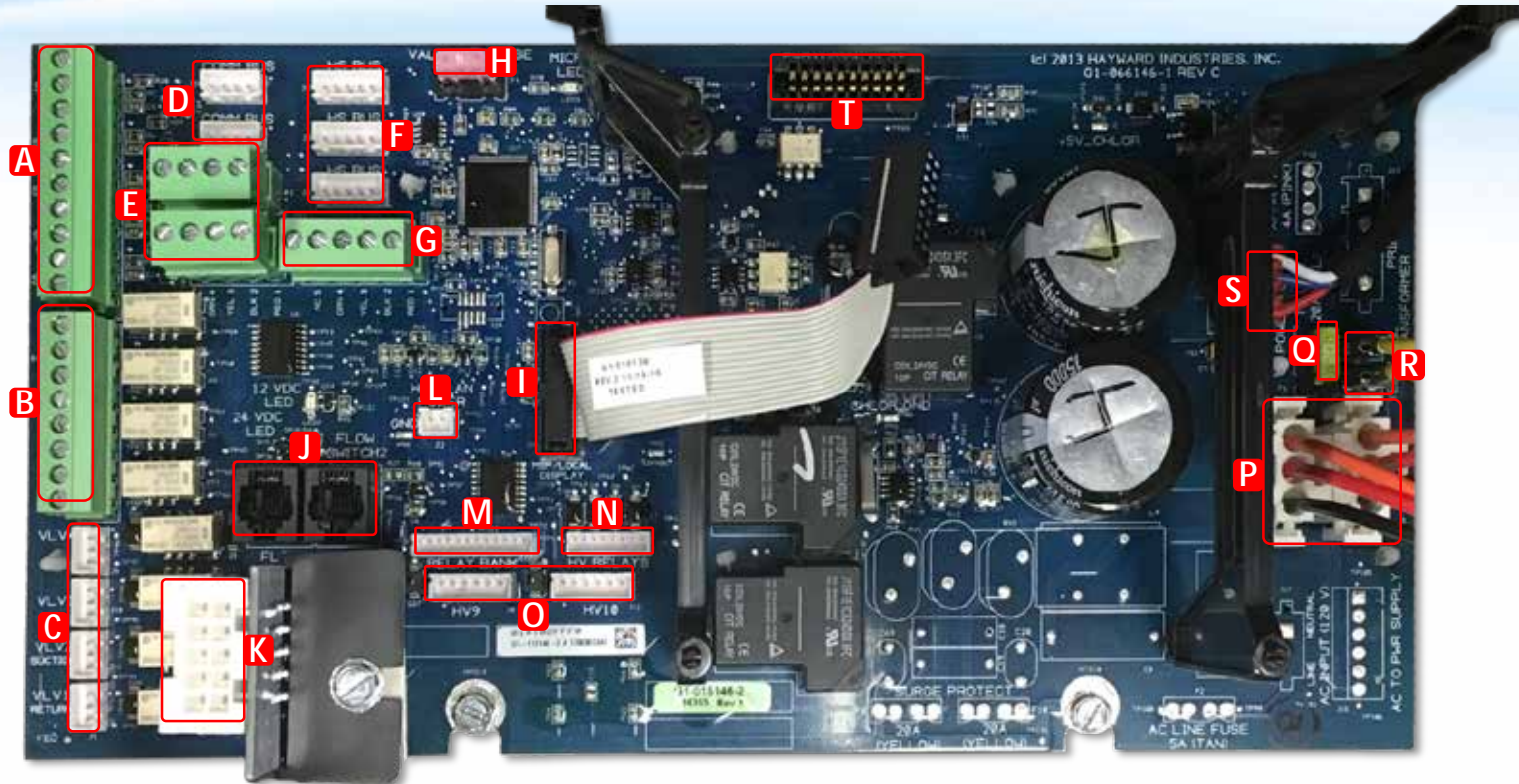

A	Sensor Blocks (SENS 1-4)	K	Turbo Cell Female Receptacle (CHLR1)
B	Low Voltage Relays (LVR 1-4)	L	WiFi Antenna LAN Power (HLWLAN)
C	Valve Actuator Ports (VLV 1-4)	M	Relay Bank Port (HVR 5-8)
D	(2) Smart Component Comm Ports	N	High Voltage Relay Port (HVR 1-4)
E	(2) RS485 Comm Terminal Blocks	O	High Voltage Relay 9 & 10 Ports (HVR 9 (Left) & 10 (Right))
F	(3) High Speed Buses	P	Rectifier Input/output AC to DC (Cell Circuit)
G	(1) High Speed Terminal Block	Q	20 Amp Fuse (Protects the Cell Circuit)
H	4 Amp Fuse (Protects Valve Actuator Circuit)	R	Transformer Output (Cell Circuit)
I	MSP Power and Comm Port (Local Display)	S	DC Output from Power Supply (Board Function Power)
J	Flow Switch Ports (FLOW SWITCH 1-2)	T	I/O Expansion Socket (For I/O Expansion Card)

OmniLogic: Main System Processor (MSP)



HLX-LOC-DSP

A2	Ethernet Port (used for both Wired & Wi-Fi network operation)
B2	USB Port (uploading firmware & backing up/loading configuration)
C2	MSP Connection (Input/Output)
D2	MSP Ribbon Cable
E2	MPP Connection (Input/Output)

OmniLogic: Wi-Fi Bridge (HLWLAN)

Injector

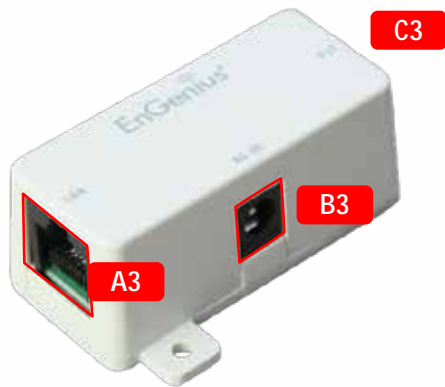

HLWLANAU

A3	LAN Port (Ethernet cable from LAN port to MSP)
B3	Power to Injector (power cable plugs into the MPP)
C3	PoE Port (Ethernet cable from PoE to LAN (PoE) of the HLWLAN)
D3	UNUSED
E3	LAN (PoE) Port (Ethernet cable from the LAN (PoE) to PoE of the injector)
F3	PWR LED (indicates HLWLAN has Power over Ethernet from injector)
G3	LAN LEDs (indicate connection with local area network)
H3	WLAN (should only appear when SSIDs are available)
I3	Signal LED (should only appear when connected to Wi-Fi network)



OmniLogic®

How To:



How To: Download Firmware

To download the latest firmware to a USB drive go to www.hayward.com
Support Center > Automation > OmniLogic > Firmware Updates

Step 1: Right click on the link of the file you wish to download.

Step 2: Within the options menu select "Save link as..."
(Note: USB drive must already be connected to your computer).

Step 3: From the "Save As" window navigate to the desired USB drive.
(Note: please make sure to select the root directory of the USB drive).

Step 4: Before saving, change the "Save as type" to "All Files" AND remove the ".txt" file extension that automatically appears. Then click on "Save" button.
(Note: failing to remove the .txt file extension will result in an unreadable firmware upgrade file).

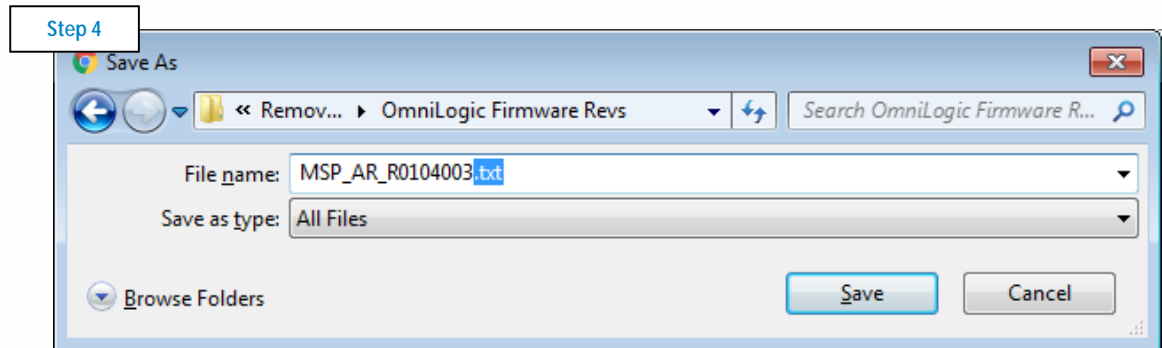
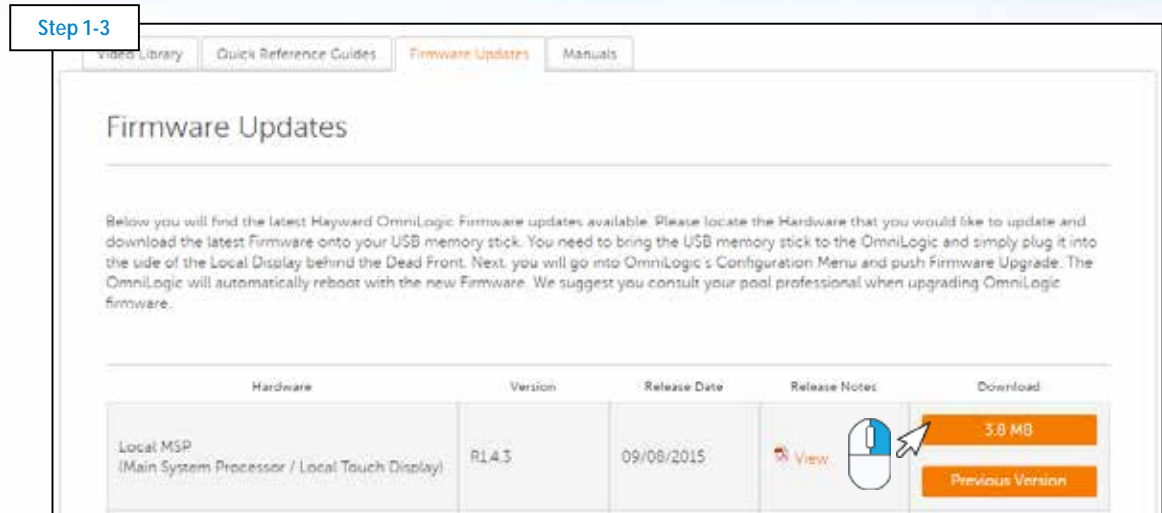

This process was accomplished through [Google's Chrome Browser](http://www.google.com).

How To: Upgrade Firmware

Insert the USB drive into the side of the MSP and follow the steps provided below:

- REFER TO WARNING ON PAGE 2 BEFORE REMOVING DEAD FRONT PANEL -

Step 1



Press the power button.

Step 2

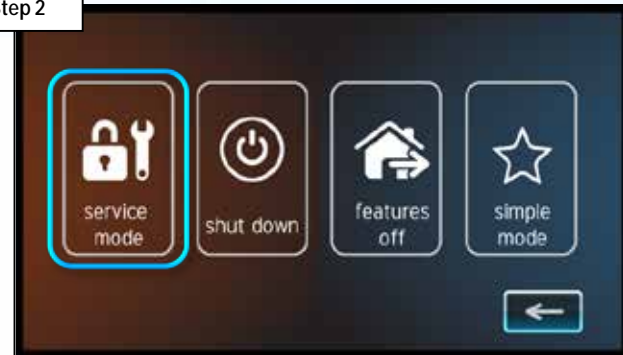

Select "service mode".

Step 3

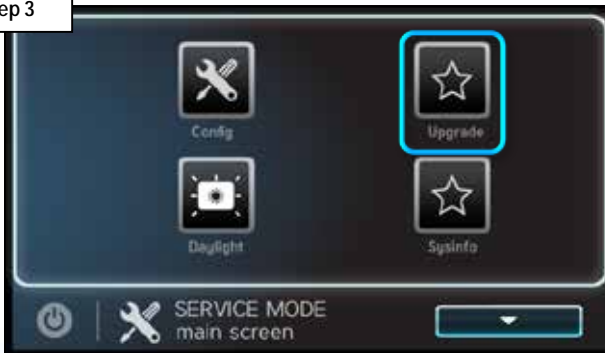

Tap the "Upgrade" icon.

Step 4



Tap device to upgrade then check mark.

How To: Upgrade Firmware (cont.)

NOTE: Make sure all devices are up to the latest firmware revision.

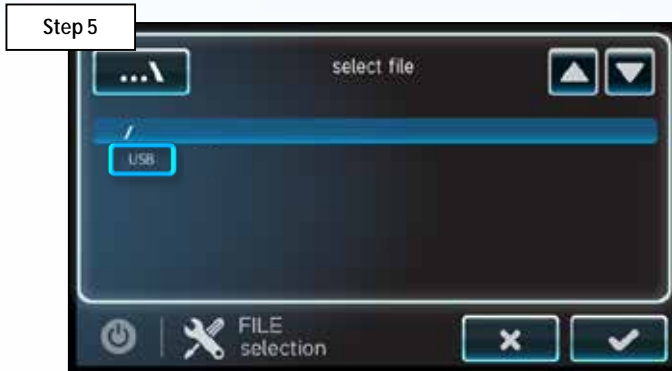

Select storage method (USB).



Select latest file (downloaded from web).

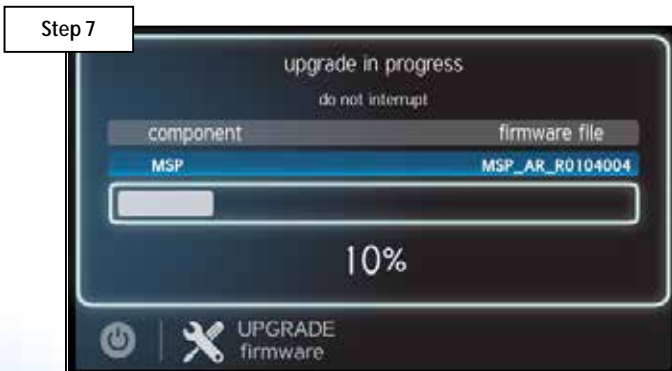

Press check mark to start the upgrade process
(DO NOT power off while in process)*.



Press check mark when complete (100%),
system will reboot.

How To: Connect Directly Via Ethernet

Use these steps to directly connect the MSP to a home router.

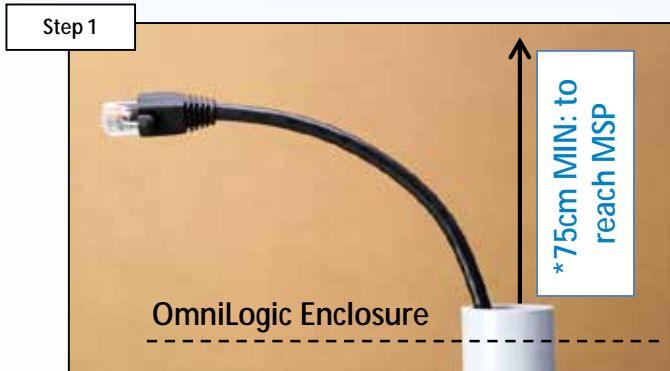

Before installing the OmniLogic, it is advisable to run Ethernet to the installation site*.

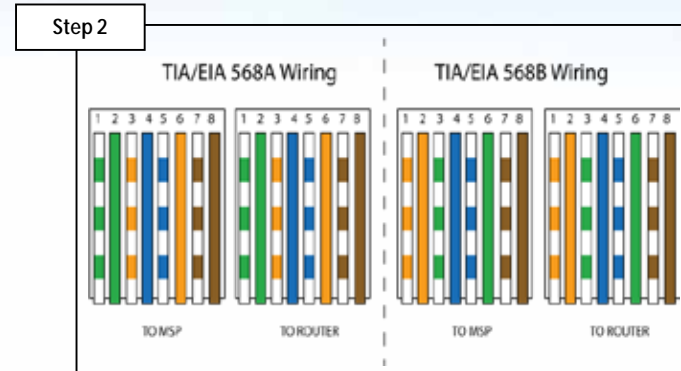

If crimping cable, follow above diagram for CAT6 (right), verify wires match.



Test the Ethernet wire using a LAN tester to confirm cable integrity and wiring. LAN testers are critical to qualifying data cabling.



Connect Ethernet cable to the router/modem. Make sure the cable IS **NOT** plugged in to a PoE or WAN port.

How To: Connect Directly Via Ethernet (cont.)

Step 5



Plug Ethernet cable into the MSP (located on the left side of the display), in the designated Ethernet port and verify LEDs illuminate.

Step 6



Once connections have been confirmed: Proceed to "How To: Create a Web Account" followed by "How To: Register an OmniLogic".

****NOTE: Both CAT5e and CAT6 type cables can be run at a maximum distance of 100m to maintain 1Gbps of data transfer; however CAT6 has more shielding which makes it less susceptible to data losses over distance.***

How To: Connect Via Wi-Fi

Use the steps provided to set up and configure the HLWLANAU to a Wi-Fi network.

prerequisite

Step 1



Connect phone or Wi-Fi enabled device to the router intended to be used with OmniLogic.

Step 2



Identify the optimal location, strongest signal, to install the HLWLAN using Ookla (free App).

Step 2B



IF download/upload speeds are less than 3Mbps, consider moving the router to a location that improves backyard Wi-Fi without forfeiting other requirements.

Step 3



Plug the short Ethernet cable provided, into the port labeled "LAN" on the injector. Then plug the other end of that same Ethernet cable into the MSP.

How To: Connect Via Wi-Fi (cont.)

PoE (Power over Ethernet): the cable plugged into the injector's "PoE" port should NEVER terminate at the MSP. Power from the injector goes to the HLWLAN ONLY.

Step 4



Plug the longer cable into "PoE" on the injector into the "LAN (PoE)" of the HLWLAN.

Step 5



Power down the OmniLogic at the isolator switch and remove the dead front - *only if qualified to do so -*

Step 6

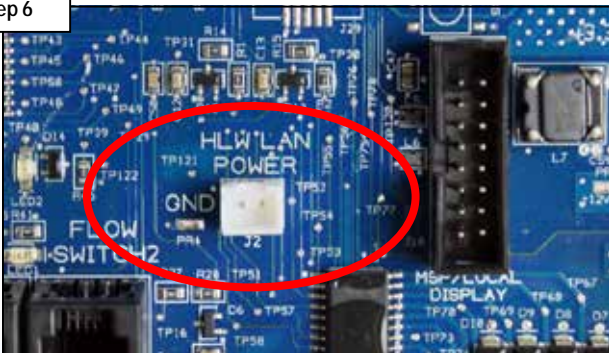

Plug the injector's power cable, into the "HLWLAN POWER" found on the OmniLogic's MPP (main board).

Step 7



Restore power to the OmniLogic. Verify the MSP's Ethernet LEDs are illuminated as well as the "PWR" and "LAN" from the HLWLAN.

How To: Connect Via Wi-Fi (cont.)

For best results, make sure the MSP firmware is updated to the latest revision:
www.hayward.com Support Center > Automation > OmniLogic > Firmware Updates

Step 8



On the right of the dashboard locate and tap the "config" icon.

Step 9



Press the "wifi bridge" option on the right side of the screen.

Step 10



Select the desired network name (SSID) to attempt connection.

Step 11



*Enter the network password, followed by the check mark to complete.

***NOTE: The network password IS CASE SENSITIVE. To confirm connection, go to Config>Network and verify IP addresses appear under the dynamic tab.**

How To: Connect Via Wi-Fi (cont.)

If creating a new account for this OmniLogic select "Register New User", otherwise log into existing account.

Step 12



Once connections have been confirmed: Proceed to "How To: Create a Web Account" (pg. 19) followed by "How To: Register an OmniLogic" (pg. 20).

How To: Create a Web Account

Use the steps provided to set up a web account for both web and app control.

Step 1



Open a web browser and type:
<http://www.haywardomnilogic.com>

Step 2



Select: "Register New User", located in the bottom left of the sign-in window.

Step 3

Fill in all the information, including username and password, then press "Save" to continue.

Step 4

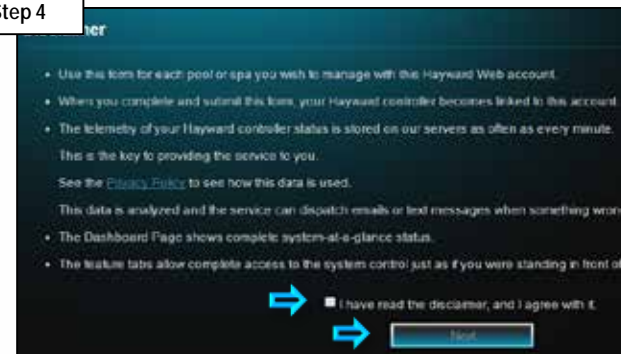

Read all listed information, including the privacy policy, check the box & press "Next".

How To: Register an OmniLogic

Use the steps provided to register an OmniLogic for web/app control. **NOTE: the OmniLogic MUST be configured AND MUST have access to the internet.**

Step 1



Enter the username and password of your account, then select "SIGN IN".

Step 2

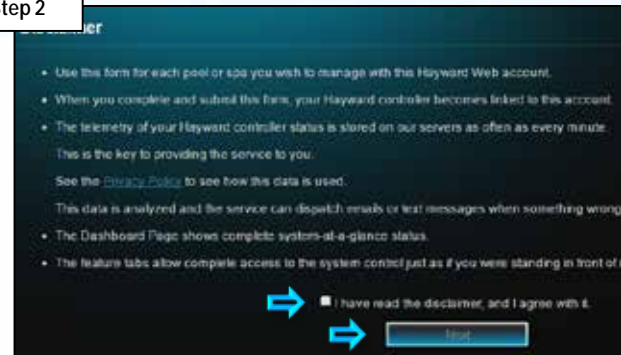

Read all listed information, including the privacy policy, check the box & press "Next".

Step 3



Read the reminder information and select "Yes" to start MSP registration.

Step 4



Fill out all required fields, including the 'MSP System ID*', then press "Save".

***NOTE: The MSP System ID can be found under config>system info (in the top banner of the screen).**

How To: Register an OmniLogic (cont.)

If registering the OmniLogic system is not successful, please go to: [Section 1, pg.26](#) to troubleshoot a Wired Network connection OR [Section 2, pg. 35](#) for Wi-Fi.



When successful, a confirmation screen will appear. If unsuccessful, go to [Section 1](#) if troubleshooting a wired network, or [Section 2](#) if troubleshooting for Wi-Fi.

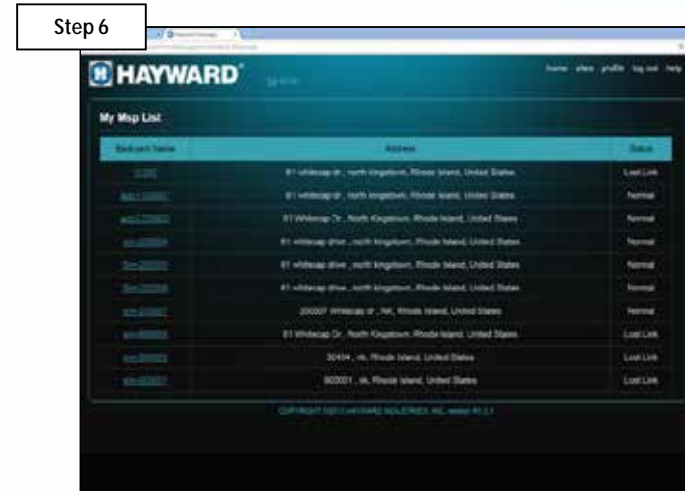

Once a unit is registered, either the dashboard will appear (bottom image of step 5) OR a table will appear (only applicable if multiple MSPs are registered to a single account).

NOTE: If the web server is unable to locate the OmniLogic system, the following message will likely appear: "MSP System ID you have input was not found, please input a valid MSP ID". If message appears, verify that the OmniLogic is powered up, the MSP is configured, and connected the home network.

How To: Safely Reboot MSP

When rebooting the OmniLogic, it is advisable to do so through the MSP and NOT directly through the isolator switch. This reboot procedure covers a safe restart.

Step 1



Press the power button.

Step 2

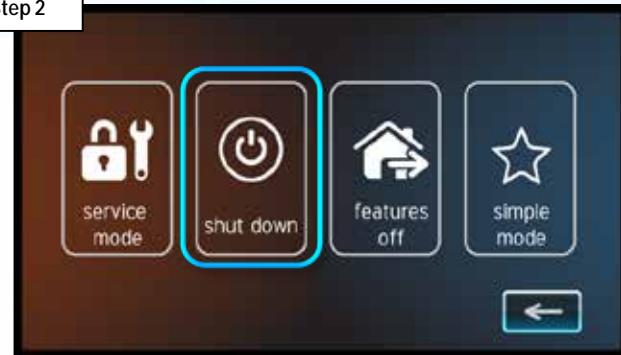

Select 'shut down'.

Step 3

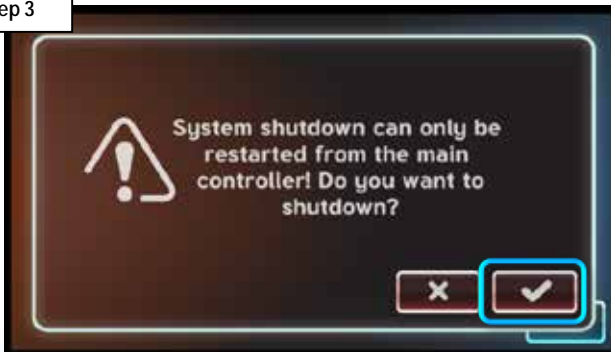

Once it is safe to reboot, a confirmation screen will appear. Press the check mark to proceed in shutting the system down.

Step 4

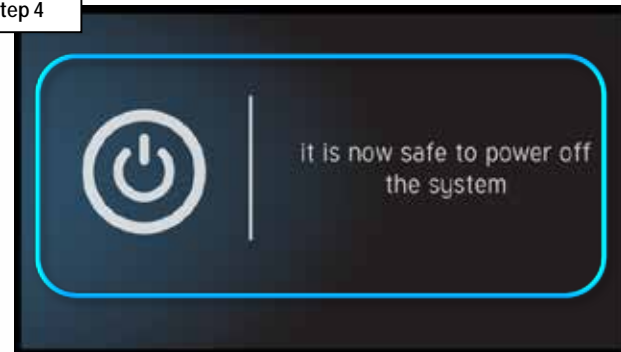

When this confirmation screen appears, tap the icon to reboot OR turn off the system breaker to power down.

How To: Connect an MSP to a Hotspot

NOTE: This process is for testing purposes ONLY. Use the steps provided to connect the MSP to a mobile Hotspot (bypasses the home network).

Step 1

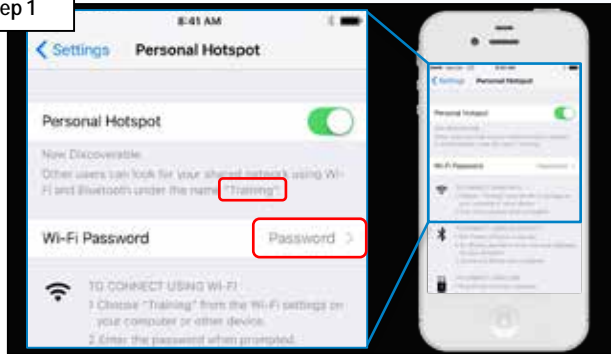

On hotspot or mobile device, identify the network name and record the password.

Step 2



Navigate to: config, then select the 'wifi bridge' to advance.

Step 3



Select the desired network name or SSID to attempt connection.

Step 4



*Enter the network password, followed by the check mark to complete.

**NOTE: The network password IS CASE SENSITIVE. To confirm connection, go to Config>Network and verify IP addresses appear under the dynamic tab.*

How To: Verify Web Server Information

The following identifies how to access Web Server information. If the IP addresses and Port #s are incorrect, registration and/or remote operation will not be possible.

Step 1

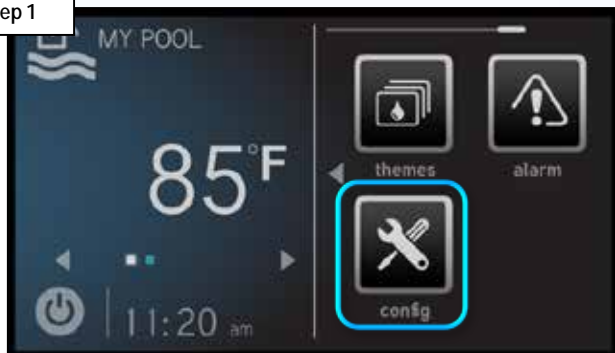

On the right of the dashboard locate and tap the "config" icon.

Step 2



Press the "web server" option on the right side of the screen.

Step 3

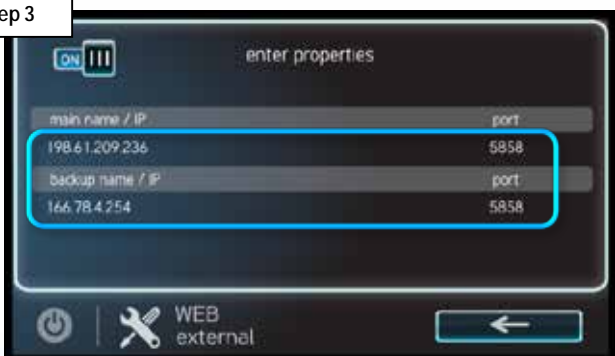

Verify that the main IP address is: 198.61.209.236 and backup: 166.78.4.254.

Step 4



*To change, select the IP address, enter correct value, and select check to save.

***WARNING: ONLY CHANGE THESE ADDRESSES IF they do not match those outlined on step 3.**



OmniLogic®

Network Troubleshooting



1. Wired Ethernet: "MSP Not Found"

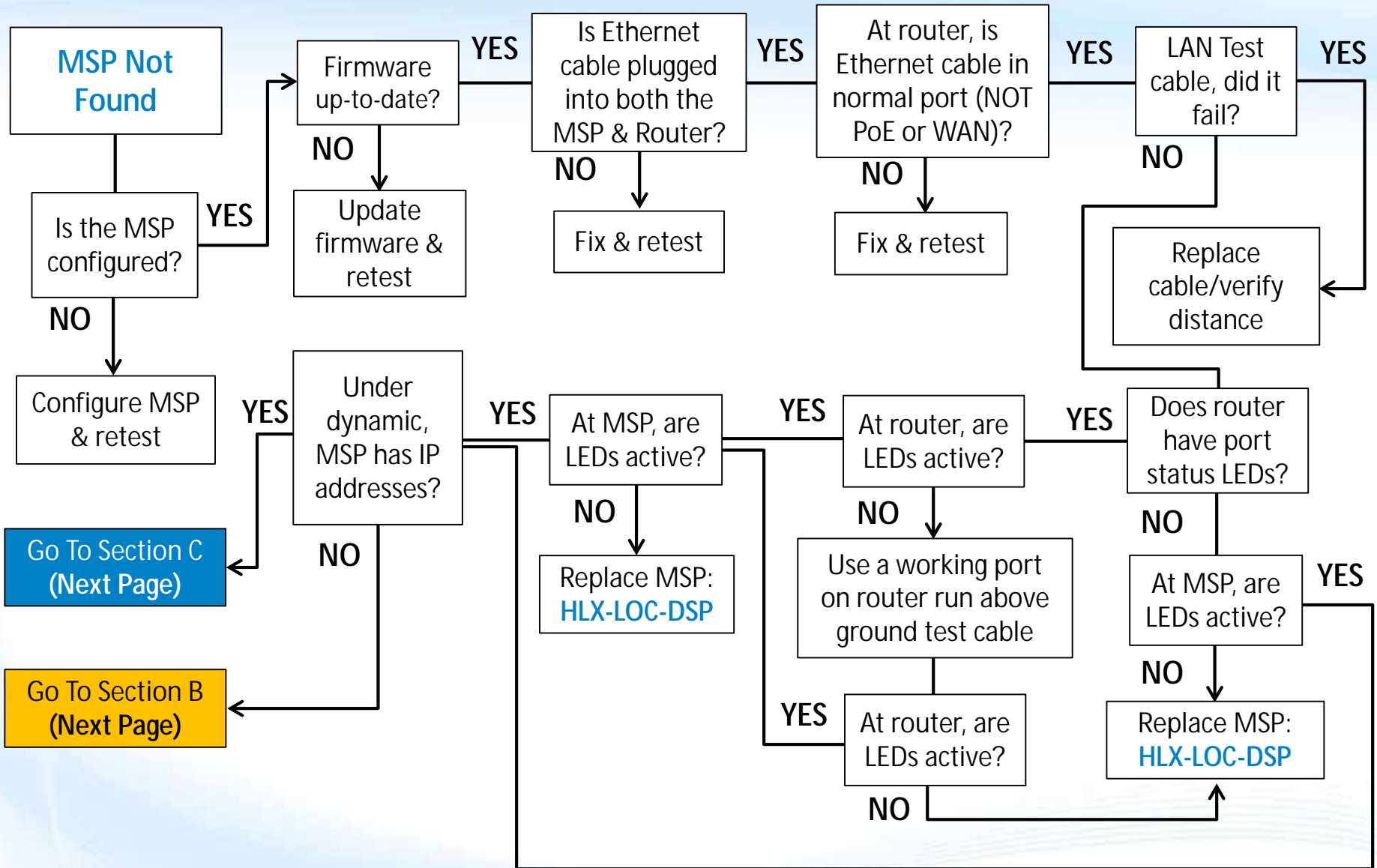

1. Wired Ethernet: "MSP Not Found" (cont.)

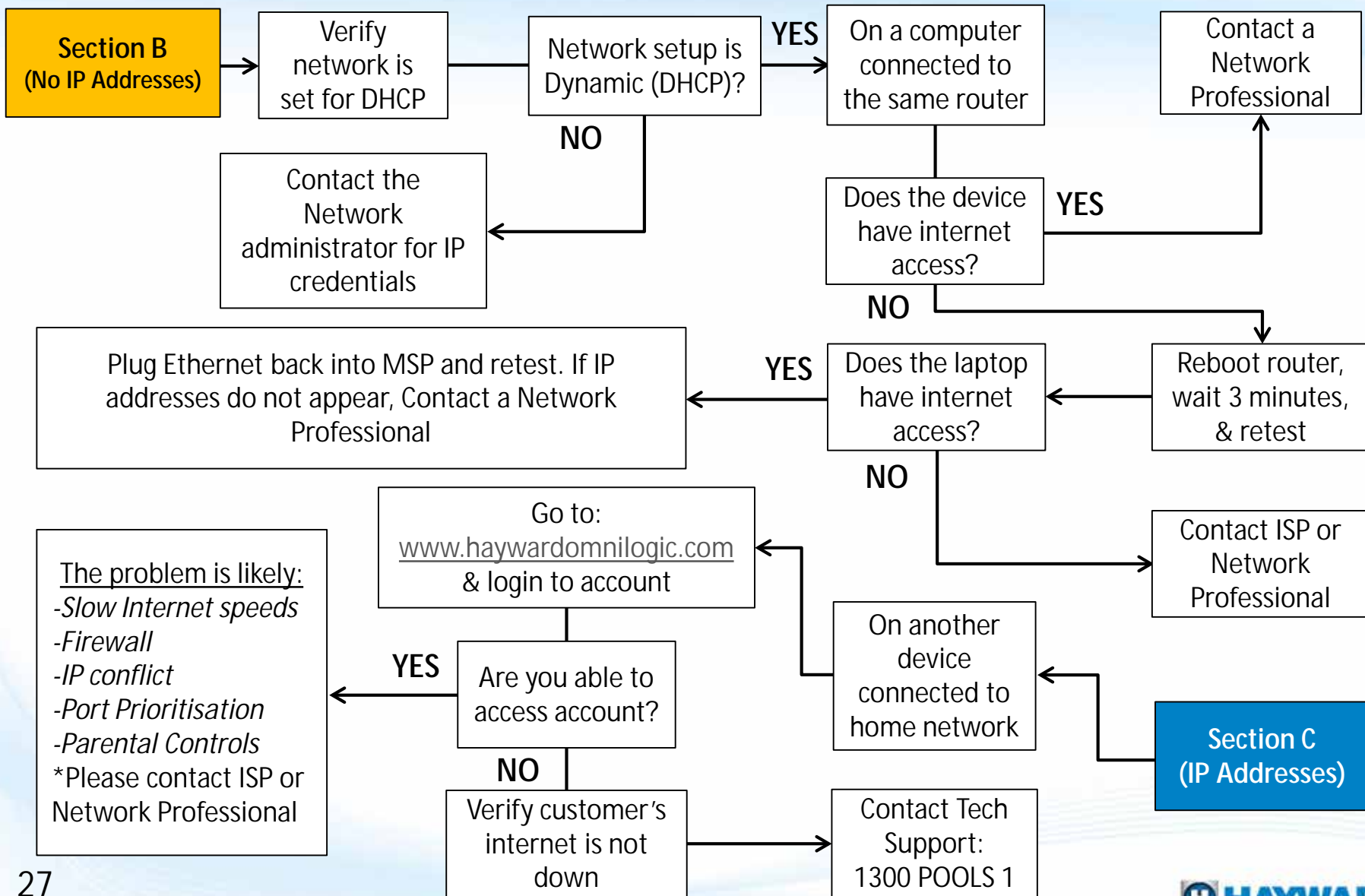

1. Wired Ethernet: "MSP Not Found"

If the OmniLogic system has not been configured, web registration will not be successful. If not configured, load a backed-up file or complete the configuration process before continuing.

Verify MSP is Configured

Step 1A



When configured, system dashboard will appear. When not configured or it has been removed, the configuration icon will default in the center of the screen (as shown above). IF configured, go to step 1B. IF not, complete the configuration process & retest.

Verify the Firmware is up-to-date

Step 1B



Locate the 'config' icon & go to system info. Verify the MSP rev. matches the latest found at www.hayward.com Support Center > Automation > OmniLogic > Firmware Updates (under MSP). IF not, follow steps on pg. 10-12. IF correct, go to step 1C.

1. Wired Ethernet: “MSP Not Found” (cont.)

PoE or Power over Ethernet typically only appears in switches or sophisticated routers. The WAN port should be reserved for internet feed into the router ONLY. DO NOT plug the MSP's Ethernet cable into a PoE or WAN port

Verify Ethernet connections

Step 1C

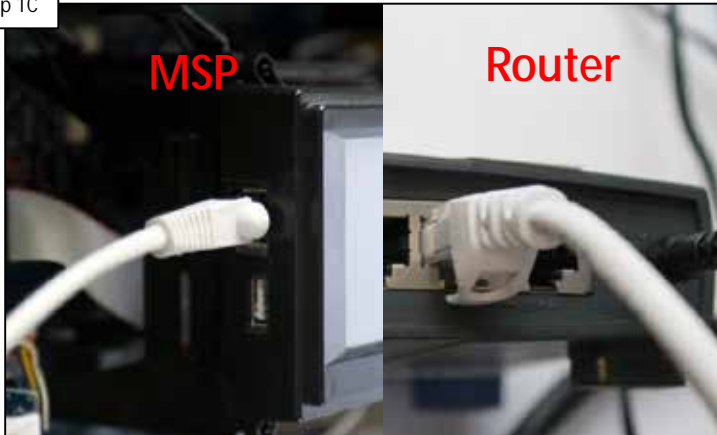

Verify the Ethernet cable is securely connected on BOTH the MSP and at the Router/modem. IF correct, go to step 1D. IF not, secure any loose connections.

Verify router port type

Step 1D



Verify the Ethernet cable that runs between the MSP and router/modem is not plugged into a PoE or WAN port. IF correct, go to step 1E. IF not, correct & retest.

1. Wired Ethernet: "MSP Not Found" (cont.)

CAT5e and CAT6 cables are rated for 100m to maintain 1Gbps; however, CAT6 has more shielding which makes it less susceptible to data losses over distance. If run exceeds 100m, contacting a network professional is advised.

Test Ethernet cable

Step 1E



Using a LAN tester, verify the Ethernet cable passes for continuity and wire configuration. IF the cable passes, go to step 1F. IF the cable fails the LAN test, replace cable & retest*.

Inspect router/modem port

Step 1F



Verify LEDs appear, where the Ethernet cable plugs into the router/modem port. IF LEDs are NOT active, go to step 1G. IF correct OR router does not have status LEDs, go to step 1H.

****NOTE: Ethernet wires that are kinked, damaged, miss-wired, or extend a distance greater than 100m typically fail a LAN test. Running a replacement cable, above ground, from the router to the MSP, an easy way to determine whether the cable is the sole culprit of the problem.***

1. Wired Ethernet: "MSP Not Found" (cont.)

**NOTE: It is advisable, for testing purposes, to temporarily run a new Ethernet cable above ground directly from the router to the MSP (THIS IS FOR TESTING PURPOSES ONLY). Use an off-the-shelf cable OR a fully verified cable.*

Plug into an active router port

Step 1G



First, identify a port on the router that remains active, temporarily disconnect the Ethernet cable*, and plug a temporary patch cable in. Plug the cable into the MSP. If the router's LEDs are still not active, replace the MSP (HLX-LOC-DSP). If active go to step 1H.

Inspect MSP's Ethernet port

Step 1H



On the MSP, verify that at least one LED is active. When both LEDs are active it confirms a connection is made AND data is being transferred back and forth. IF LEDs are ON, go to step 1I. IF NOT, replace MSP: (HLX-LOC-DSP).

WARNING: Prior to disconnecting any other cables from the router, first note the cable and its position. ALWAYS get permission to disconnect cables as this can affect the devices' operation.

1. Wired Ethernet: "MSP Not Found" (cont.)

Most networks run Dynamic (DHCP); this means the router issues IP addresses to connected devices. Static networks, although rare in residential applications, require programmed IP credentials to make full connection with the router.

Check for IP addresses

Step 1I



On the MSP, go to config>network. Verify the Network is set to Dynamic AND IP addresses appear under 'local IP', 'netmask, & 'gateway'*. IF they DO NOT appear, go to 1J. IF IP addresses appear AND registration is still unsuccessful, jump to step 1M.

Verify the router is set to DHCP

Step 1J

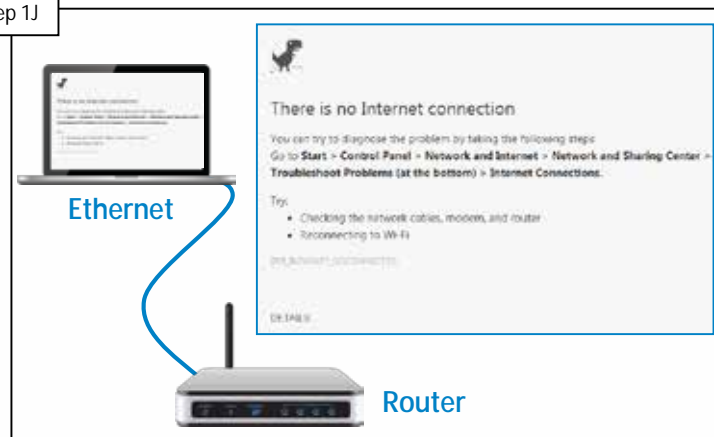

Verify the router is issuing IP addresses based off DHCP. To get out to the internet, if owner simply plugs into the router, then it is DHCP. IF DHCP, go to step 1K. IF static, IP credentials must be provided to continue, contact the network administrator for this information.

NOTE: When the MSP is in Daylight mode when dynamic is selected it should have a grey background.

1. Wired Ethernet: “MSP Not Found” (cont.)

Routers may take as long as 3 minutes to fully reboot after power is returned. To power cycle, it is recommended to unplug the router from its power source as apposed to pressing any reset buttons (reset buttons can reset some routers to factory default).

Laptop/PC test

Step 1K



On a computer or laptop connected to the same router, verify whether or not the device has internet access. IF NO internet, go to step 1L. IF internet access is available please contact a network professional for more assistance.

Reboot router/modem

Step 1L



Reboot the router and modem (if applicable), wait three minutes & retest. Verify whether or not internet access is available. IF Internet access is available, reattempt registration. Contact a network professional IF registration fails or NO internet access is available.

1. Wired Ethernet: "MSP Not Found" (cont.)

Verify the account through www.haywardomnilogic.com is accessible. If not accessible from the customer's network, reattempt using a hotspot; if cellular/hotspot still does not work, contact tech support: 1300 POOLS 1.

Laptop/PC test

Step 1M

The image displays two side-by-side screenshots of the Hayward web interface. The left screenshot shows the login page with the Hayward logo at the top. Below the logo is a form with a 'User Name' field containing 'techservice', a 'Password' field with masked characters, and a 'Remember Login Name' checkbox. A 'SIGN IN' button is at the bottom of the form. Below the form are links for 'Register New User' and 'Forgot Password?'. The right screenshot shows a 'Disclaimer' page with the Hayward logo and navigation links (home, sites, profile, log out, help). The disclaimer text includes: 'Use this form for each pool or spa you wish to manage with this Hayward Web account.', 'When you complete and submit this form, your Hayward controller becomes linked to this account.', 'The telemetry of your Hayward controller status is stored on our servers as often as every minute. This is the key to providing the service to you. See the Privacy Policy to see how this data is used. This data is analyzed and the service can dispatch emails or text messages when something wrong is detected.', 'The Dashboard Page shows complete system-at-a-glance status.', and 'The feature tabs allow complete access to the system control just as if you were standing in front of it.' At the bottom of the disclaimer is a checkbox 'I have read the disclaimer, and I agree with it.' and a 'Next' button. A copyright notice 'COPYRIGHT ©2013 HAYWARD INDUSTRIES, INC. version: 31.0.12' is at the very bottom.

On a computer or laptop connected to the same router, Go to www.haywardomnilogic.com & log into the account created for this OmniLogic. IF unable to access this account, verify the customer's internet is NOT down and contact technical support. IF able to access the account, please call a network professional for more assistance*.

**Access to the account may imply one of the following: Internet speeds are slow, a firewall is prohibiting MSP to Web interaction, there is an IP conflict on the network, port prioritization is affecting traffic, or parental controls within the router are disrupting communication.*

2. Wi-Fi Connection: "MSP Not Found"

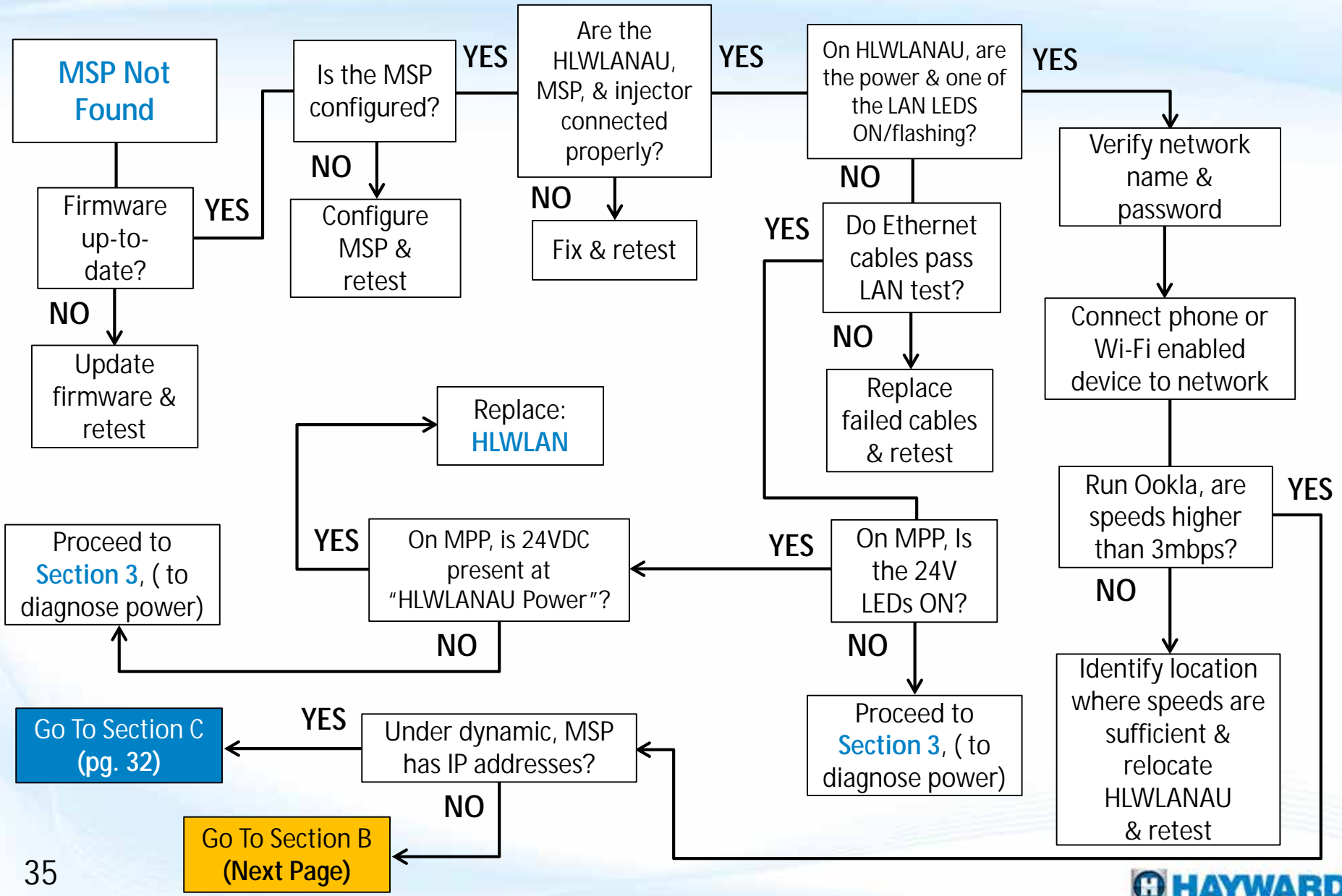

2. Wi-Fi Connection: "MSP Not Found" (cont.)

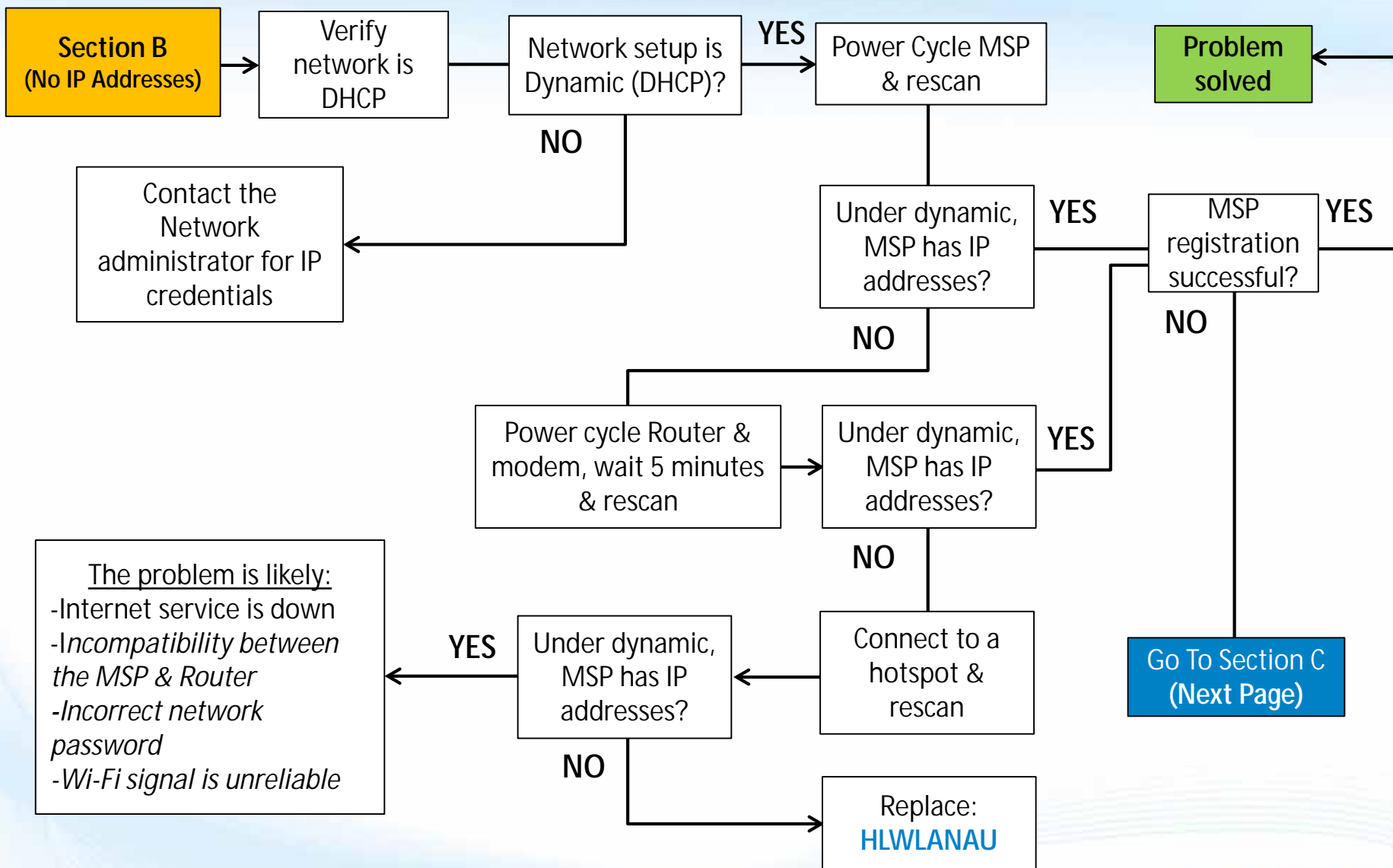

2. Wi-Fi Connection: "MSP Not Found" (cont.)

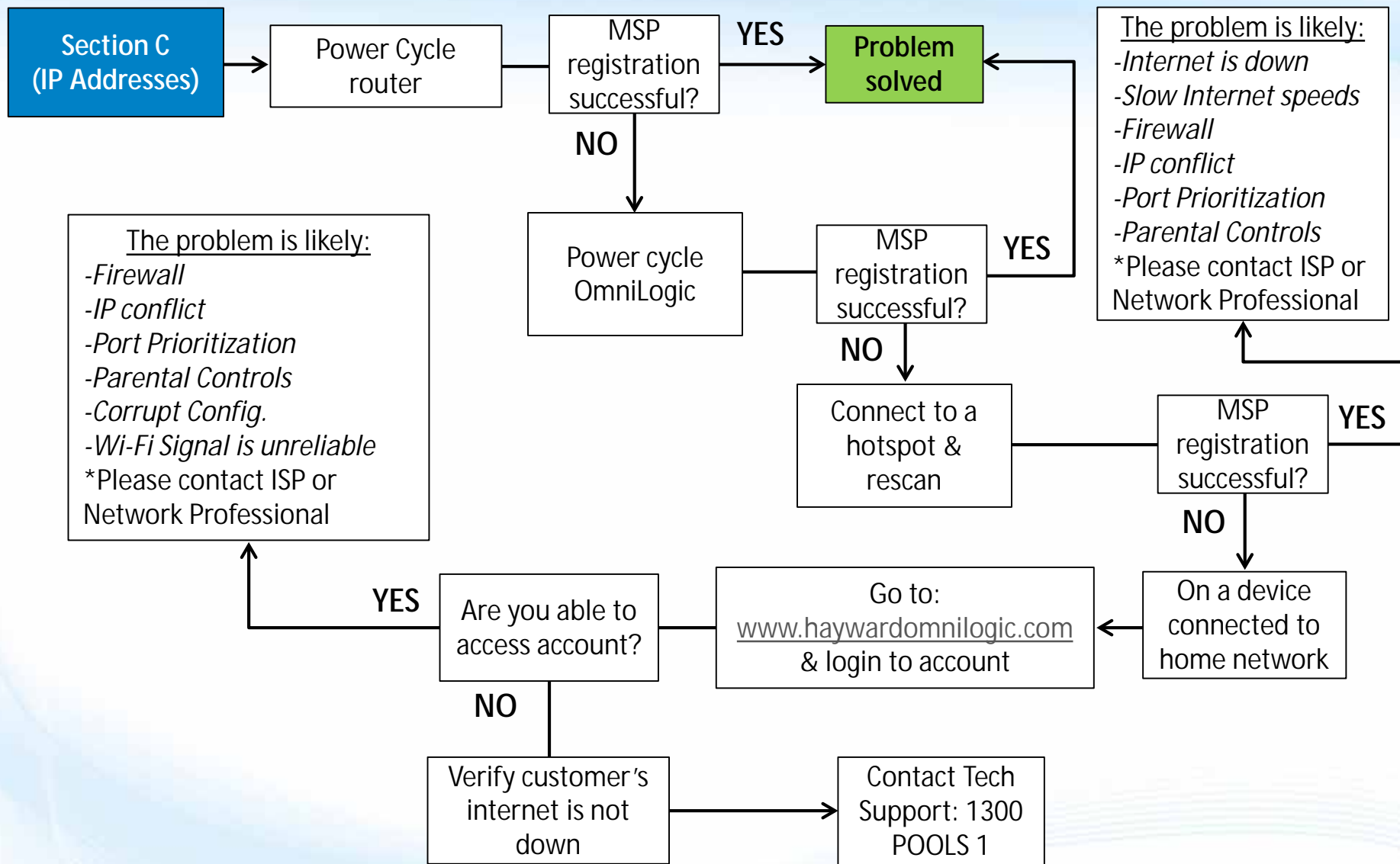

2. Wi-Fi Connection: “MSP Not Found”

If the OmniLogic system has not been configured, web registration will not be successful. If not configured, load a backed-up file or complete the configuration process before continuing.

Verify the Firmware is up-to-date

Step 2A



Locate the 'config' icon & go to system info. Verify the MSP rev. matches the latest found at www.hayward.com Support Center > Automation > OmniLogic > Firmware Updates (under MSP). IF not, follow steps on pg. 10-12. IF correct, go to step 1B.

Verify MSP is Configured

Step 2B



When configured, system dashboard will appear. When not configured or it has been removed, the configuration icon will default in the center of the screen (as shown above). IF configured, go to step 1C. IF not, complete the configuration process & retest.

2. Wi-Fi Connection: "MSP Not Found" (cont.)

NOTE: DO NOT hold down the reset button (back of the HLWLANAU) for more than 10 seconds.

Verify HLWLANAU connections

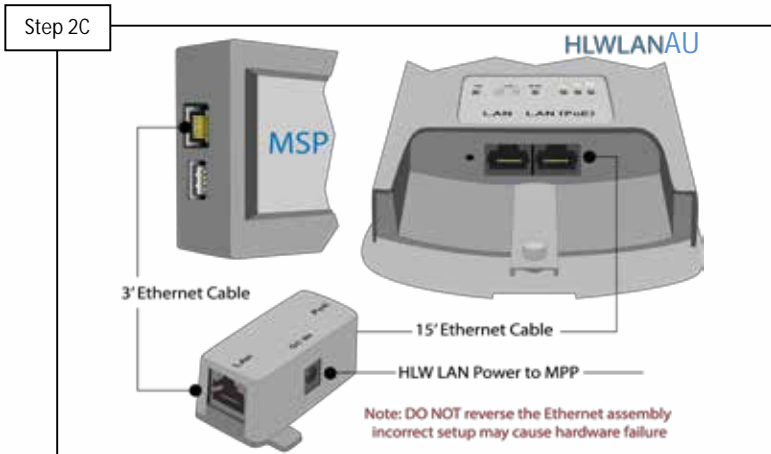

Verify the cable from the MSP is plugged into the LAN port on the injector. Then verify the cable plugged into the HLWLANAU's LAN (POE) port plugs into the injectors POE port. Finally, verify the injectors power cable is plugged firmly into the OmniLogic MPP. IF correct, go to step 2D. IF incorrect, fix & repeat steps on [pg. 15-18](#).

On HLWLANAU, inspect LEDs



On the back of the HLWLANAU, verify both the Power LED & at least one of the LAN LEDs is ON or Flashing. This will indicate whether or not power has been supplied to the HLWLANAU and if communication has been established with the local area network. IF LEDs are not ON, go to 2E. IF correct, jump to step 2H.

2. Wi-Fi Connection: “MSP Not Found” (cont.)

LAN testers are crucial tools for testing the integrity AND proper configuration of network cabling. They are readily available through Network Supply Stores.

Conduct LAN test on cables

Step 2E



Unplug both Wi-Fi cables and conduct a LAN test on each cable, using a LAN tester. IF cable(s) fail the LAN test, replace all failed cables. IF both cables pass, go to step 2F.

Inspect 24V LED on MPP

Step 2F



On the MPP, verify the 24V LED is illuminated. IF the LED is ON or you are unsure, go to step 2G. IF the LED is clearly off, proceed to [Section 3 \(pg. 48\)](#) to diagnose system power.

2. Wi-Fi Connection: “MSP Not Found” (cont.)

Unless changed by the homeowner or network installer, the SSID (network name) and the default password are often published on the router.

Verify 24VDC on MPP

Step 2G

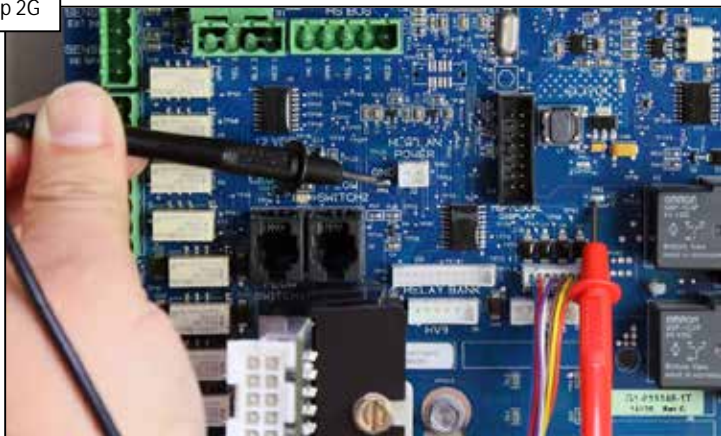

Unplug MSP and check between the 24VDC and GND solder points for 24VDC. IF voltage is correct, replace the [HLWLANAU](#). IF no/low voltage, proceed to [Section 3 \(pg. 48\)](#) to diagnose system power.

Network name & password

Step 2H



Verify the network name & password are both correct. NOTE: passwords **ARE** case sensitive, should not include the '&' symbol, **AND** no spaces. IF correct go to step 2I, otherwise correct through the network router.

2. Wi-Fi Connection: “MSP Not Found” (cont.)

NOTE: When connecting to a customer’s network from a Wi-Fi enabled device (such as a smart phone) DO NOT connect to any 5Ghz networks as these are not supported by the HLWLANAU.

Connect a Wi-Fi enabled device

Step 2I



On a Wi-Fi enabled device, connect to customer’s network. Run the Ookla app (speed test). IF speed is/above 3Mb for download & upload, go to 2J. IF lower than 3Mb/3Mb, identify a location where speeds consistently exceed 3Mb/3Mb & relocate the HLWLANAU to this location; then rescan & attempt registration.

Check for IP addresses

Step 2J



On the MSP, go to config>network. Verify the network is set to Dynamic AND that IP addresses appear under ‘local IP’, ‘netmask, & ‘gateway’*. IF IP addresses DO NOT appear, go to 2K. IF addresses appear AND registration is still unsuccessful, jump to step 2P to determine why registration is still unsuccessful.

**NOTE: When the MSP is in Daylight mode and dynamic is selected it should have a grey background.*

2. Wi-Fi Connection: "MSP Not Found" (cont.)

Some routers may have a power button and others have a reset button. Unplugging the power cable at the router will ensure it is not reset to factory default.

Attempt registration

Step 2M



The screenshot shows a web form titled "Register MSP" with the following fields and options:

- Backyard Name: [Text input]
- Msp System ID: [Text input]
- First Name/Last Name: [Text input]
- Address: [Text input]
- Address Line 2: [Text input]
- City: [Text input]
- State: [Dropdown menu: Select one]
- Zip: [Text input]
- Country: [Dropdown menu: United States]
- Phone Number: [Text input]
- Time Zone: [Dropdown menu: Select one]
- Daylight Saving Time: [Checkbox]
- Receive Alarm Message: [Checkbox]
- Buttons: Register, Go Back

Go to www.haywardomnilogic.com, log in to the account & reattempt registration. IF registration is successful, then the problem is solved. IF unsuccessful, jump to step 2P.

Power cycle the router

Step 2N



Unplug the power to the router. Once completely down, plug the power back in and wait 5 minutes, then rescan. IF IP addresses appear, back-up to step 2M. IF NO IP addresses, go to step 2O.

2. Wi-Fi Connection: "MSP Not Found" (cont.)

NOTE: Mobile hotspots generally rely on cellular service. For best results, make sure cellular service is 3G or better when conducting a mobile hotspot test. Unplugging the power cable at the router will ensure it is not reset to factory default.

Connect to a Hotspot

Step 20

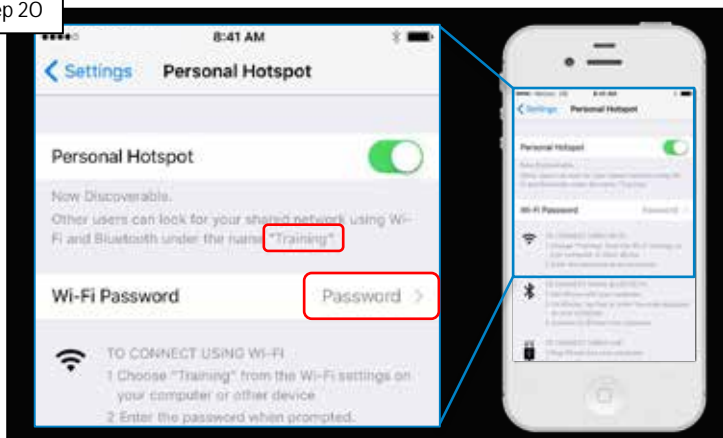

Setup a mobile hotspot and connect the MSP to that hotspot (pg. 23). Check for IP addresses in the MSP. IF still NO IP addresses, then replace the HLWLANAU. IF IP addresses appear, contact a network professional*.

Power cycle the router

Step 2P



Unplug the power to the router, once completely down, plug the power back in and wait 5 minutes, then attempt registration. IF successful, problem is solved. IF unsuccessful go to 2Q.

**IF IP addresses appear after connecting to a hotspot then the problem is likely related to: internet service is down, incorrect network password, Wi-Fi signal is unreliable, OR incompatibility between the MSP & Router. NOTE: There have been reported compatibility problems with Pace/U-verse, modem/router combos; adding a third party router may resolve the issue.*

2. Wi-Fi Connection: “MSP Not Found” (cont.)

NOTE: Mobile hotspot generally rely on cellular service. For best results, make sure cellular service is 3G or better when conducting a mobile hotspot test.

Power cycle MSP

Step 2Q



On the MSP, power cycle the MSP (pg. 22). When the OmniLogic boots back up wait 3 minutes & attempt registration. IF successful, problem is solved. IF unsuccessful go to 2R.

Register while connected (Hotspot)

Step 2R

Setup a mobile hotspot and connect the MSP to that hotspot (pg. 23). Attempt registration. IF still NO IP addresses, then go to 2S. IF Registration is successful, contact a network professional*.

**IF IP addresses appear after connecting to a hotspot then the problem is likely related to: Internet is down, slow Internet speeds, firewall, IP conflict, port prioritization, or parental controls.*

2. Wi-Fi Connection: “MSP Not Found” (cont.)

NOTE: If experiencing trouble logging into the web account, verify the username and password are correct (the password IS CASE SENSITIVE).

Log into OmniLogic account

Step 2S

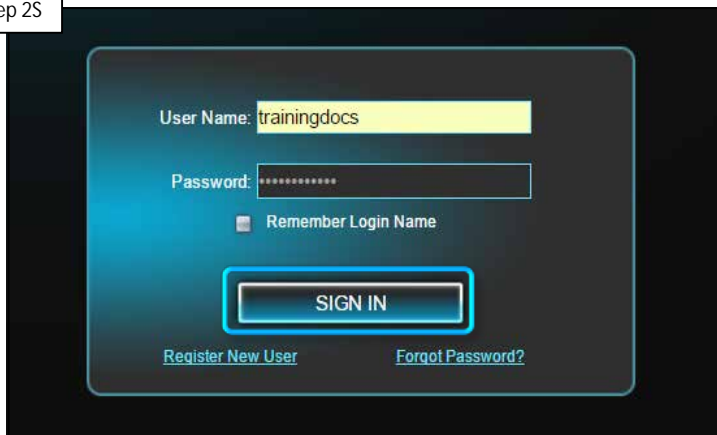

User Name: trainingdocs

Password: *****

Remember Login Name

SIGN IN

[Register New User](#) [Forgot Password?](#)

On a device connected to the network, go to www.haywardomnilogic.com and complete login. IF login was unsuccessful, verify the customer's internet is not down and contact tech support 1300 POOLS 1. IF login was successful, please contact a network professional for more assistance*.

**IF IP addresses appear after connecting to a hotspot then the problem is likely related to: Firewall, IP conflict, port prioritization, parental controls, corrupt config., or Wi-Fi signal is unreliable.*

3. 24V LED Not Illuminated

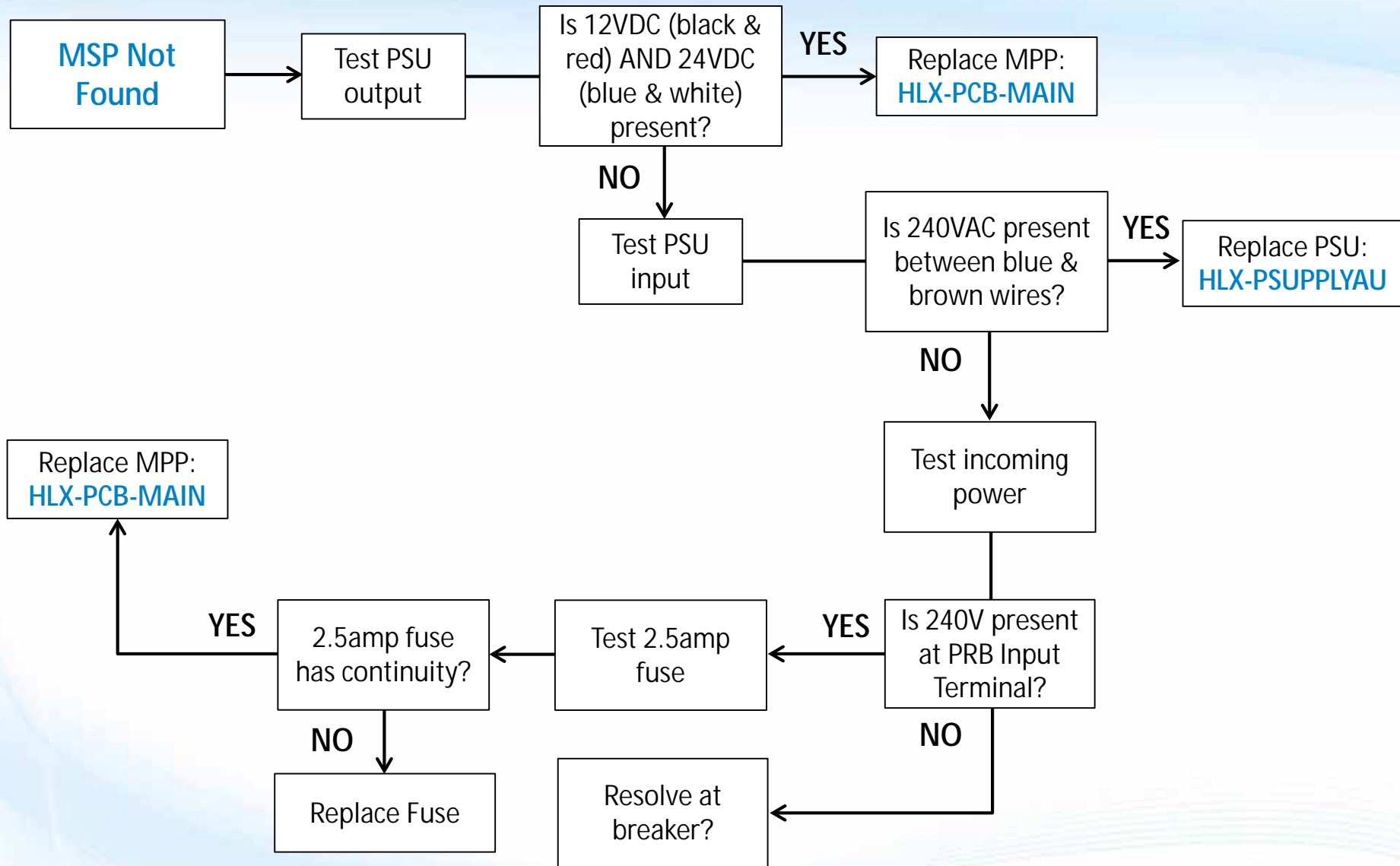

3. 24V LED Not Illuminated

The power supply (located in the lower right portion of the cabinet) converts 240VAC to 12VDC and 24VDC. The 12vDC circuit drives communication and the 24VDC circuit drives relay activation.

Test PSU output

Step 3A



Check for 12VDC between the black and red (bottom two) wires and 24VDC between blue and white (top two). IF voltage is correct, replace MPP ([HLX-PCB-MAIN](#)). IF low/no voltage, go to 3B.

Test PSU input

Step 3B

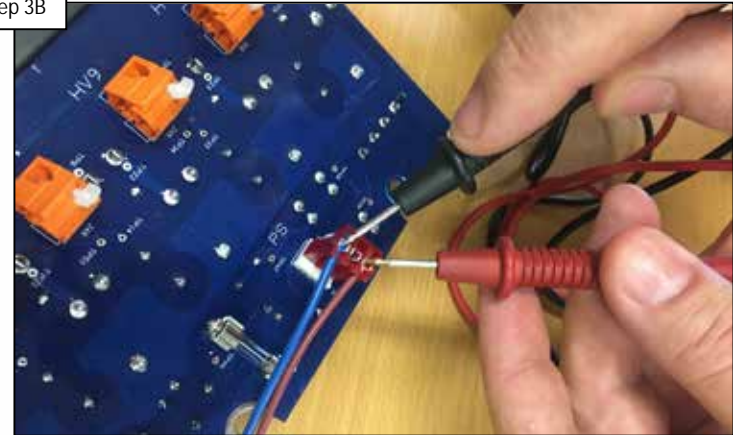

Test between the blue and brown wires for 240VAC. IF no/low, continue to step 3C. IF voltage is correct, then the power supply will need to be replaced ([HLX-PSUPPLYAU](#)).

