



# HYDRAHEAT HEAT PUMP



## HEAT PUMP UNIT

### Installation & Operation Manual

To prevent potential injury and to avoid unnecessary service calls, read this manual carefully and completely. Retain and ensure this manual is passed on to the end user.

Hayward Pool Products (Australia) Pty Ltd. Melbourne-Sydney-Brisbane-Perth  
Email: [sales@hayward-pool.com.au](mailto:sales@hayward-pool.com.au) | Website: [au.hayward.com](http://au.hayward.com)  
PO Box 4384 | Dandenong South VIC 3164  
ABN 66 083 413 414 Sales  
Contact Ph: 1300POOLS1 Fax: 1300POOLS2



# CONTENTS

1. Preface .....	1
2. Specifications .....	4
2.1 Performance Data of Swimming Pool Heat Pump Unit .....	4
2.2 The dimensions for Swimming Pool Heat Pump Unit .....	8
3. Installation and Connection .....	12
3.1 Installation illustration .....	12
3.2 Swimming Pool Heat Pumps Location .....	13
3.3 How Close to Your Pool? .....	13
3.4 Swimming Pool Heat Pumps Plumbing .....	14
3.5 Swimming Pool Heat Pumps Electrical Wiring .....	15
3.6 Initial Start-up of the Unit .....	15
4. Use and Operation Instruction .....	16
4.1 General presentation .....	16
4.2 Timer function settings .....	18
4.3 Setting the On/Off timers .....	19
4.4 PV Ready function .....	21
4.5 Spot time .....	24
4.6 Adjust setpoint .....	25
4.7 Locking and unlocking the touch screen .....	26
4.8 Silent function settings .....	27
4.9 Troubleshooting guide .....	30
4.10 Parameter list and breakdown table .....	31
4.11 Interface drawing .....	33
5. Maintenance and Inspection .....	38
6. Maintenance and Inspection .....	45
7. Appendix .....	50
7.1 Cable specification .....	50
7.2 Comparison table of refrigerant saturation temperature .....	51

# 1. PREFACE

---

- This product has been manufactured according to stringent production standards to ensure quality, reliability, and versatility for our customers. This manual contains comprehensive instructions regarding the installation, troubleshooting, maintenance, and disposal of the device. It is essential to thoroughly review this handbook prior to installing or operating the item. The manufacturer of this device disclaims all liability for injuries or damages caused by faulty installation or inappropriate maintenance. Strict adherence to the directions in this manual is essential. The installation must only be carried out by qualified personnel.
- The unit can only be repaired by an authorised dealer.
- Maintenance and operation must be carried out according to the recommended time and frequency, as stated in this manual.
- Use genuine spare parts only.  
Failure to comply with these recommendations will invalidate the warranty.
- Swimming Pool Heat Pump Unit heats the swimming pool water and keeps the temperature constant.
- Our heat pump has following characteristics:

## 1 Durability

The heat exchanger is made of PVC & Titanium tubing which can withstand prolonged contact with swimming pool water.

## 2 Installation flexibility

The unit can be installed indoors or outdoors.

## 3 Quiet operation

The unit comprises an efficient rotary/ scroll compressor and a low-noise fan motor, which guarantees its quiet operation.

## 4 Advanced controlling

The unit includes micro-computer controlling, allowing all operation parameters to be set. Operation status can be displayed on the LCD controller and Aqua Temp App

## WARNING

It is advised against making any attempts to speed up the defrosting process or clean the evaporator using methods not specified in this manual.

The appliance shall be stored in a room without continuously operating ignition sources (for example: open flames, an Operating gas appliance or an operating electric heater.)

Do not pierce or burn.

Be aware that refrigerants may not contain an odour,

Appliance shall be installed, operated and stored in a room with a floor area larger than 30m<sup>2</sup>.

NOTE The manufacturer may provide other suitable examples or may provide additional information about the refrigerant odour.



# 1. PREFACE(Continued)

---

- This appliance is not intended for use by persons (including children) with reduced physical, sensory or mental capabilities, or lack of experience and knowledge, unless they have been given supervision or instruction concerning use of the appliance by a person responsible for their safety. CHILDREN SHOULD BE SUPERVISED TO ENSURE THAT THEY DO NOT PLAY WITH THE APPLIANCE.
- If the supply cord is damaged, it must be replaced by the manufacturer, its service agent or similarly qualified persons in order to avoid a hazard.
- The appliance shall be installed in accordance with national wiring regulations.
- Do not operate the appliance in a wet room such as a bathroom or laundry room.
- Before obtaining access to terminals, all supply circuits must be disconnected.
- Power to the heat pump shall be provided through all pole disconnection device or electrical isolator with having pole to pole clearance of at least 3mm.
- Do not use means to accelerate the defrosting process or to clean, other than those recommended by the manufacturer
- The appliance shall be stored in a room without continuously operating ignition sources (for example: open flames, an operating gas appliance or an operating electric heater.)
- Do not pierce or burn
- Appliance shall be installed, operated and stored in a room with a floor area larger than 30m<sup>2</sup>

Be aware that refrigerants may not contain an odour.

The installation of pipe-work shall be kept to a minimum 30 m Max

Spaces where refrigerant pipes shall be compliance with national gas regulations.

Service shall be performed only as recommended by the manufacturer.

The appliance shall be stored in a well-ventilated area where the room size corresponds to the room area as specified for operation.

All working procedure that affects safety means shall only be carried by competent persons.

- Transport of equipment containing flammable refrigerants  
should be compliance with the transport regulations  
Equipment signs are marked to have compliance with local regulations  
Equipment and flammable refrigerants must be disposed of in accordance with national rules.
- Storage of equipment/appliances  
The storage of equipment should be in accordance with the manufacturer's instructions.
- Storage of packed (unsold) equipment  
The equipment packing was designed to guard against any mechanical damage that would cause refrigerant leaks.  
Local regulations may apply on how many units are allowed to be stored together.

# 1. PREFACE(Continued)

---

## Caution & Warning

1. The unit can only be repaired by qualified installer centre personnel or an authorised dealer. (for Europe market)
2. This appliance is not intended for use by persons (including children) with reduced physical sensory or mental capabilities, or lack of experience and knowledge, unless they have been given supervision or instruction concerning use of the appliance by a person responsible for their safety. (for Europe market)  
Children should be supervised to ensure that they do not play with the appliance.
3. Please make sure that the unit and power connection have good earthing, otherwise may cause electrical shock.
4. If the supply cord is damaged, it must be replaced by the manufacturer or our service agent or similarly qualified person in order to avoid a hazard.
5. Directive 2002/96/EC (WEEE):  
The symbol depicting a crossed-out waste bin that is underneath the appliance indicates that this product, at the end of its useful life, must be handled separately from domestic waste, must be taken to a recycling centre for electric and electronic devices or handed back to the dealer when purchasing an equivalent appliance.
6. Directive 2002/95/EC (RoHS): This product is compliant with directive 2002/95/EC (RoHS) concerning restrictions for the use of harmful substances in electric and electronic devices.
7. The unit CANNOT be installed near the flammable gas. Once there is any leakage of the gas, fire can occur.
8. All electrical connections must be made by a qualified electrician in accordance with all local state federal government electrical regulations and the latest edition of AS/NZS 3000 wiring rules.
9. USE SUPPLY WIRES SUITABLE FOR 75°C.
10. This equipment is not suitable for potable water connection.

## 2.SPECIFICATION

### 2.1 Performance data of Swimming Pool Heat Pump Unit

\*\*\* REFRIGERANT: R32

UNIT		1H-PASRW030EE12	1H-PASRW040EE17
Rated Heating Capacity (27°C/24.3°C)	kW	1.970~11.66	2.90~17.0
	Btu/h	6720-39780	9890-58000
Rated Heating Power Input	kW	0.12-1.99	0.18-3.12
COP		16.40-5.86	16.10-5.45
Rated Heating Capacity (15°C/12°C)	kW	1.79-8.62	2.80-13.10
	Btu/h	6110-29410	9550-44700
Rated Heating Power Input	kW	0.25-1.91	0.40-2.97
COP		7.20-4.52	7.00-4.41
Power Supply		220-240V~/50Hz	220-240V~/~50Hz
Compressor Quantity		1	1
Compressor		Rotary	Rotary
Fan Quantity		1	1
Fan Rotate Speed	RPM	300-950	400-750
Noise	dB(A)	42-53	43-54
Water Connection	mm	48.3	48.3
Water Flow Volume	m <sup>3</sup> /h	3.7	5.2
Water Pressure Drop(max)	kPa	4.0	5.0
Unit Net Dimensions(L/W/H)	mm	998x418x604	1047x453x766
Unit Ship Dimensions(L/W/H)	mm	See package lable	
Net Weight	kg	46	60
Shipping Weight	kg	see package label	
Rated Input Current	A	10.9	16.56
Gas charge weight	kg	0.48	0.6

Heating: Outdoor air temp: 27°C/24.3°C, Inlet water temp:26°C

Outdoor air temp: 15°C/12°C, Inlet water temp:26°C

Operating range:

Ambient temperature:-5—43°C

Water temperature:9-40°C

## 2.SPECIFICATIONS

---

### 2.1 Performance data of Swimming Pool Heat Pump Unit

\*\*\* REFRIGERANT: R32

UNIT		1H-PASRW050EE19
Heating capacity (27/24.3℃)	kW	3.50-18.70
	Btu/h	11900-63800
Heating Power Input	kW	0.22-3.65
COP		16.0-5.12
Heating capacity (15/12℃)	kW	2.55-14.00
	Btu/h	8500-49980
Heating Power Input	kW	0.36-3.24
COP		7.10-4.32
Power Supply		220-240V~/50Hz
Compressor Quantity		1
Compressor		rotary
Fan Number		1
Fan Power Input	W	75
Fan Rotate Speed	RPM	750
Fan Direction		horizontal
Noise	dB(A)	43-55
Water Connection	mm	48.3
Water Flow Volume	m <sup>3</sup> /h	6.0
Water Pressure Drop(max)	kPa	5.0
Unit Net Dimensions(L/W/H)	mm	1161x490x860
Unit Ship Dimensions(L/W/H)	mm	See package lable
Net Weight	kg	70
Shipping Weight	kg	See package lable
Input rated current	A	17.5
Gas charge weight	kg	0.67

Heating: Outdoor air temp: 27℃/24.3℃, Inlet water temp:26℃

Outdoor air temp: 15℃/12℃, Inlet water temp:26℃

Operating range:

Ambient temperature:-7—43℃

Water temperature:9-40℃

## 2.SPECIFICATION

### 2.1 Performance data of Swimming Pool Heat Pump Unit

\*\*\* REFRIGERANT: R32

UNIT		1H-PASRW060EE24	1H-PASRW070EE29	1H-PASRW080EE32
Rated Heating Capacity (27°C/24.3°C)	kW	8.700~24.60	9.80~28.6	10.30~32.40
	Btu/h	29680-83930	33430-97570	35140~110540
Rated Heating Power Input	kW	0.54-3.89	0.61-4.17	0.64-5.90
COP		16.10-6.30	16.00-6.90	16.00-5.50
Rated Heating Capacity (15°C/12°C)	kW	7.000-19.10	7.20-21.80	7.90~24.40
	Btu/h	23880-65170	24560-74370	26950~83250
Rated Heating Power Input	kW	0.990-3.980	0.94-4.22	1.08~5.53
COP		7.10-4.80	7.60-5.20	7.30~4.40
Power Supply		220-240V~/50Hz	380-400V/3N~/50Hz	380-400V/3N~/50Hz
Compressor Quantity		1	1	1
Compressor		Rotary	Rotary	Rotary
Fan Quantity		1	1	1
Fan Rotate Speed	RPM	600-800	600-700	600-700
Noise	dB(A)	45-56	45-57	45-57
Water Connection	mm	48.3	48.3	48.3
Water Flow Volume	m <sup>3</sup> /h	10.0	12.0	12.0
Water Pressure Drop(max)	kPa	14.0	17.0	17.0
Unit Net Dimensions(L/W/H)	mm	1161x490x862	1161x490x862	1161x490x862
Unit Ship Dimensions(L/W/H)	mm	See package lable		
Net Weight	kg	92	96	93
Shipping Weight	kg	see package label		
Rated Input Current	A	22.5	10.22	11.70
Gas charge weight	kg	1.15	1.35	1.35

Heating: Outdoor air temp: 27°C/24.3°C, Inlet water temp:26°C

Outdoor air temp: 15°C/12°C, Inlet water temp:26°C

Operating range:

Ambient temperature:-15—43°C

Water temperature:9-40°C

## 2.SPECIFICATION

---

### 2.1 Performance data of Swimming Pool Heat Pump Unit

\*\*\* REFRIGERANT : R32

UNIT		1H-PASRW070EE35
Heating capacity (27/24.3℃)	kW	7.43-34.94
	Btu/h	25350-119215
Heating Power Input	kW	0.460-6.533
COP		16.10-5.35
Heating capacity (15/12℃)	kW	5.32-26.97
	Btu/h	18150-92020
Heating Power Input	kW	0.75-6.180
COP		7.09-4.36
Power Supply		380-400V/3N~/50Hz
Compressor Quantity		1
Compressor		rotary
Fan Number		2
Noise	dB(A)	48.0-56.0
Water Connection	mm	48.3
Water Flow Volume	m <sup>3</sup> /h	10
Water Pressure Drop(max)	kPa	15
Unit Net Dimensions(L/W/H)	mm	1161x490x1272
Unit Ship Dimensions(L/W/H)	mm	See package lable
Net Weight	kg	120
Shipping Weight	kg	see package label
Rated input Current	A	12.84
Gas charge weight	kg	1.5

Heating: Outdoor air temp: 27℃/24.3℃, Inlet water temp:26℃

Outdoor air temp: 15℃/12℃, Inlet water temp:26℃

Operating range:

Ambient temperature:-15—43℃

Water temperature:9-40℃

# 2.SPECIFICATION

## 2.2 The dimensions for Swimming Pool Heat Pump Unit

Model:1H-PASRW030EE12

unit: mm

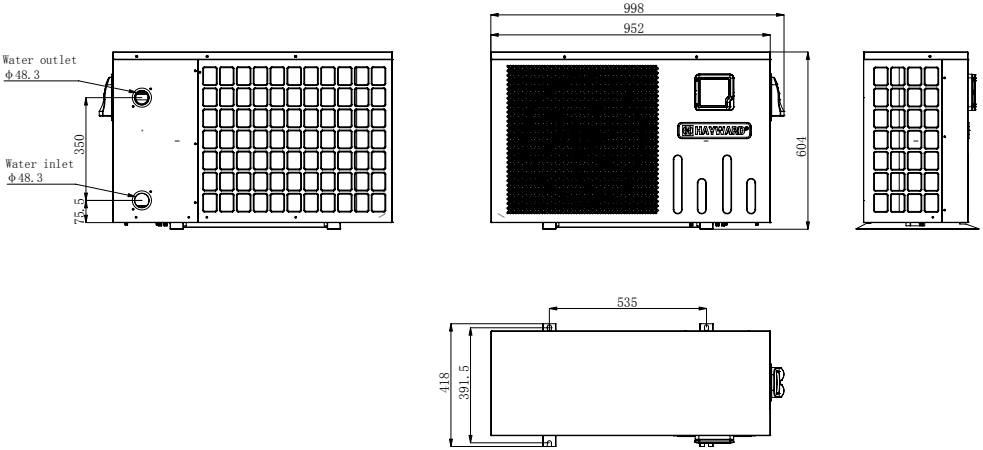

Model:1H-PASRW040EE17

unit: mm

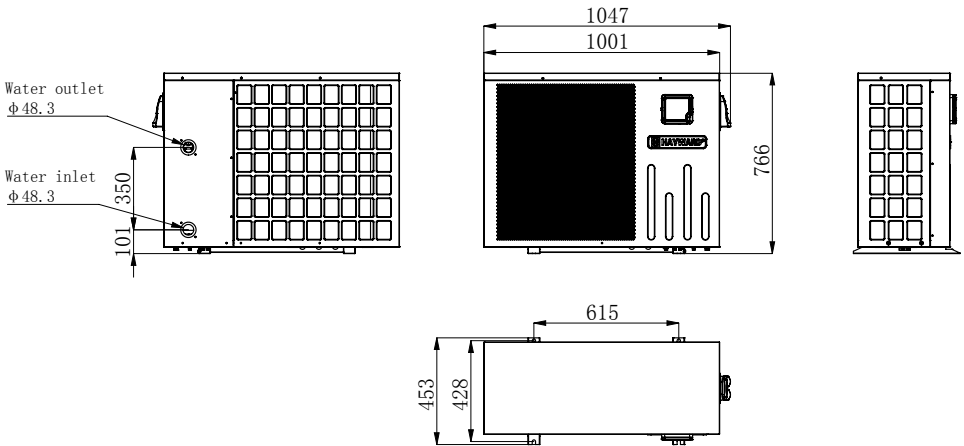

# 2.SPECIFICATIONS

## 2.2 The dimensions for Swimming Pool Heat Pump Unit

Model:1H-PASRW050EE19

unit mm

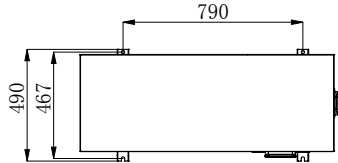
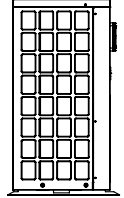
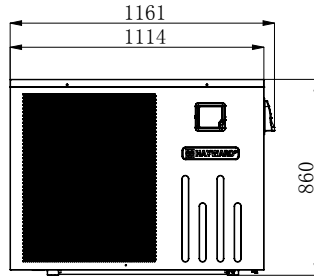
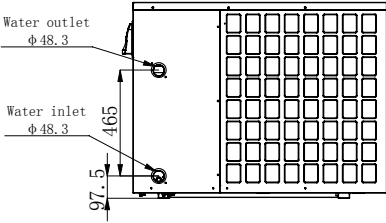

## 2.SPECIFICATION

---

### 2.2 The dimensions for Swimming Pool Heat Pump Unit

Model: 1H-PASRW060EE24  
1H-PASRW070EE29  
1H-PASRW080EE32

unit: mm

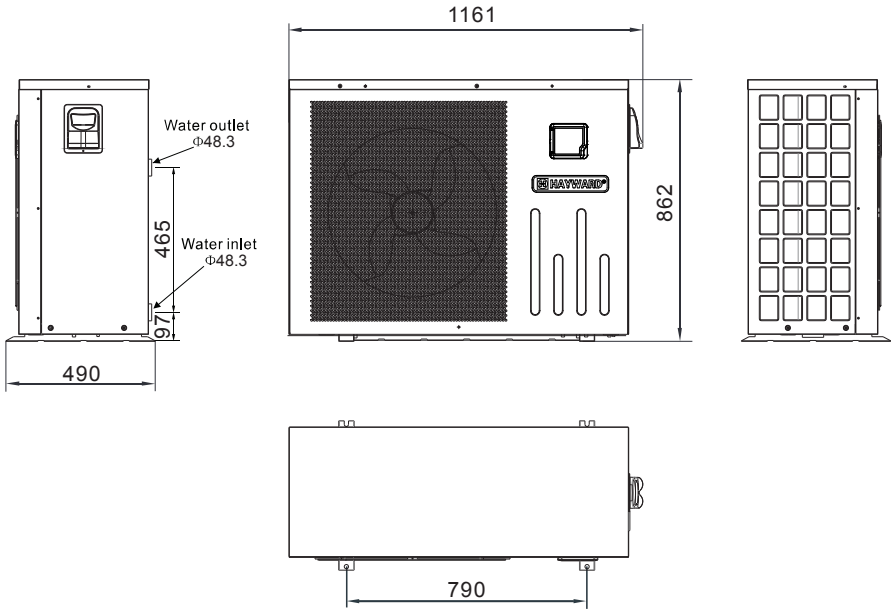

# 2.5 SPECIFICATION

---

## 2.2 The dimensions for Swimming PoolHeat Pump Unit

UNIT: 1H-PASRW070EE35

unit :mm

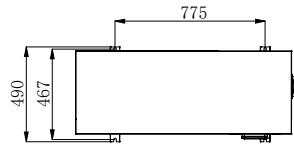
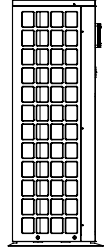
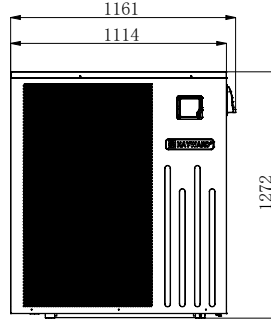
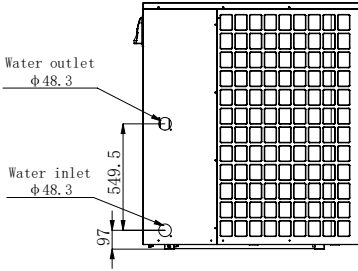

# 3.INSTALLATION AND CONNECTION

---

## 3.1 Installation illustration

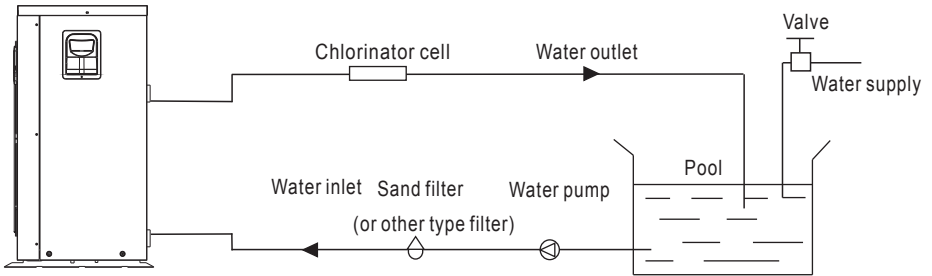

### Installation items:

The factory only provides the main unit and the water unit; the other items in the illustration are necessary spare parts for the water system, that provided by users or the installer.

### Attention:

Please follow these steps when using for the first time

1. Open valve and charge water.
2. Make sure that the pump and the water-in pipe have been filled with water.
3. Close the valve and start the unit.

ATTN: It is necessary that the water-in pipe is higher than the pool surface.

The schematic diagram is for reference only. Please check the water inlet/outlet label on the heat pump while plumbing installation.

The schematic diagram is for reference only. Please check the water inlet/outlet label on the heat pump while plumbing installation.

The controller is mounted on the wall

# 3. INSTALLATION AND CONNECTION

---

## 3.2 Swimming Pool Heat Pumps Location

The unit will perform well in any outdoor location provided that the following three factors are presented:

1. Fresh Air -
2. Electricity -
3. Pool filter piping

The unit may be installed virtually anywhere outdoors. For indoor pools please consult the supplier. Unlike a gas heater, it has no draft or pilot light problem in a windy area.

DO NOT place the unit in an enclosed area with a limited air volume, where the units discharge air will be re-circulated.

DO NOT place the unit to shrubs which can block air inlet. These locations deny the unit of a continuous source of fresh air which reduces its efficiency and may prevent adequate heat delivery.

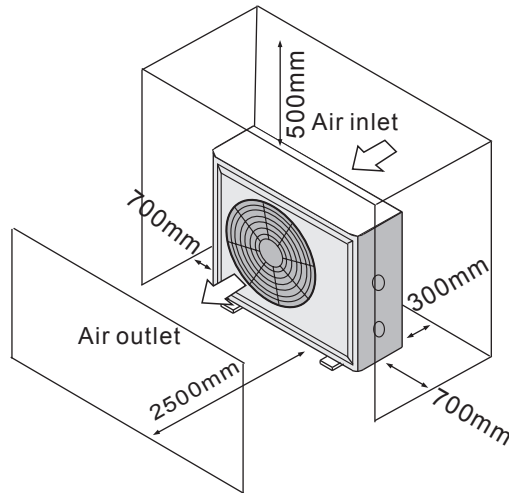

## 3.3 How Close To Your Pool?

Normally, the pool heat pump is installed within 7.5 metres of the pool. The longer the distance from the pool, the greater the heat loss from the piping. For the most part, the piping is buried. Therefore, the heat loss is minimal for runs of up to 15 meters (15 meters to and from the pump = 30 meters total), unless the ground is wet or the water table is high. A very rough estimate of heat loss per 30 meters is 0.6 kW-hour, (2000BTU) for every 5 °C difference in temperature between the pool water and the ground surrounding the pipe, which translates to about 3% to 5% increase in run time.

# 3.INSTALLATION AND CONNECTION

---

## 3.4 Swimming Pool Heat Pumps Plumbing

The Swimming Pool Heat Pumps exclusive rated flow titanium heat exchanger requires no special plumbing arrangements except bypass(please set the flow rate according to the nameplate). The water pressure drop is less than 10kPa at max. Flow rate. Since there is no residual heat or flame Temperatures, The unit does not need copper heat sink piping. PVC pipe can be run straight into the unit.

Location: Connect the unit in the pool pump discharge (return) line downstream of all filter and pool pumps, and upstream of any chlorinators, ozonators or chemical pumps.

Standard model have slip glue fittings which accept 32mm or 50 mm PVC pipe for connection to the pool or spa filtration piping. By using a 50 NB to 40NB you can plumb 40NB

Give serious consideration to adding a quick coupler fitting at the unit inlet and outlet to allow easy draining of unit for winterizing and to provide easier access should servicing be required.

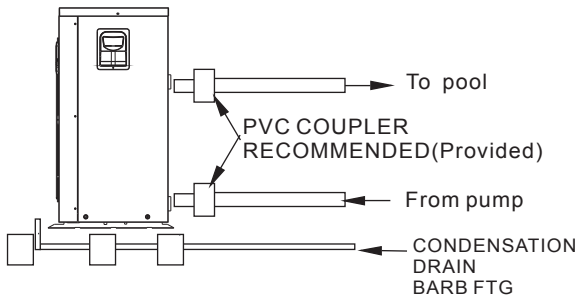

Condensation: Since the Heat pump cools down the air about 4 -5°C, water may condense on the fins of the horseshoe shaped evaporator. If the relative humidity is very high, this could be as much as several litres an hour. The water will run down the fins into the basepan and drain out through the barbed plastic condensation drain fitting on the side of the basepan. This fitting is designed to accept 20mm clear vinyl tubing which can be pushed on by hand and run to a suitable drain. It is easy to mistake the condensation for a water leak inside the unit.

NB: A quick way to verify that the water is condensation is to shut off the unit and keep the pool pump running. If the water stops running out of the basepan, it is condensation. AN EVEN QUICKER WAY IS to TEST THE DRAIN WATER FOR CHLORINE - if there is no chlorine present, then it's condensation.

## 3. INSTALLATION AND CONNECTION

---

### 3.5 Swimming Pool Heat Pumps Electrical Wiring

NOTE: Although the unit heat exchanger is electrically isolated from the rest of the unit, it simply prevents the flow of electricity to or from the pool water. Grounding the unit is still required to protect you against short circuits inside the unit. Bonding is also required.

The unit has a separate molded-in junction box with a standard electrical conduit nipple already in place. Just remove the screws and the front panel, feed your supply lines in through the conduit nipple and wire-nut the electric supply wires to the three connections already in the junction box (four connections if three phase). To complete electrical hookup, connect Heat Pump by electrical conduit, UF cable or other suitable means as specified (as permitted by local electrical authorities) to a dedicated AC power supply branch circuit equipped with the proper circuit breaker, disconnect or time delay fuse protection.

Disconnect - A disconnect means (circuit breaker, fused or un-fused switch) should be located within sight of and readily accessible from the unit. This is common practice on commercial and residential air conditioners and heat pumps. It prevents remotely-energizing unattended equipment and permits turning off power at the unit while the unit is being serviced.

### 3.6 Initial startup of the Unit

NOTE- In order for the unit to heat the pool or spa, the filter pump must be running to circulate water through the heat exchanger.

Start up Procedure - After installation is completed, you should follow these steps:

1. Turn on your filter pump. Check for water leaks and verify flow to and from the pool.
2. Turn on the electrical power supply to the unit, then press the key ON/OFF of wire controller. It should start in several seconds.
3. After running a few minutes make sure the air leaving the top(side) of the unit is cooler (Between 5-10 °C)
4. With the unit operating turn the filter pump off. The unit should also turn off automatically.
5. Allow the unit and pool pump to run 24 hours per day until desired pool water temperature is reached. When the water-in temperature reaches this setting, the unit will slow down for a period of time, if the temperature is maintained for 45 minutes the unit will turn off. The unit will now automatically restart (as long as your pool pump is running) when the pool temperature drops more than 0.2 below set temperature.

Time Delay- The unit is equipped with a 3 minute built-in solid state restart delay included to protect control circuit components and to eliminate restart cycling and contactor chatter. This time delay will automatically restart the unit approximately 3 minutes after each control circuit interruption. Even a brief power interruption will activate the solid state 3 minute restart delay and prevent the unit from starting until the 5 minute countdown is completed.

# 4. Controlling and Operation

## 4.1 General presentation

The heat pump is equipped with a digital control panel with a touch screen, electronically connected and pre-set at the factory in heating mode.

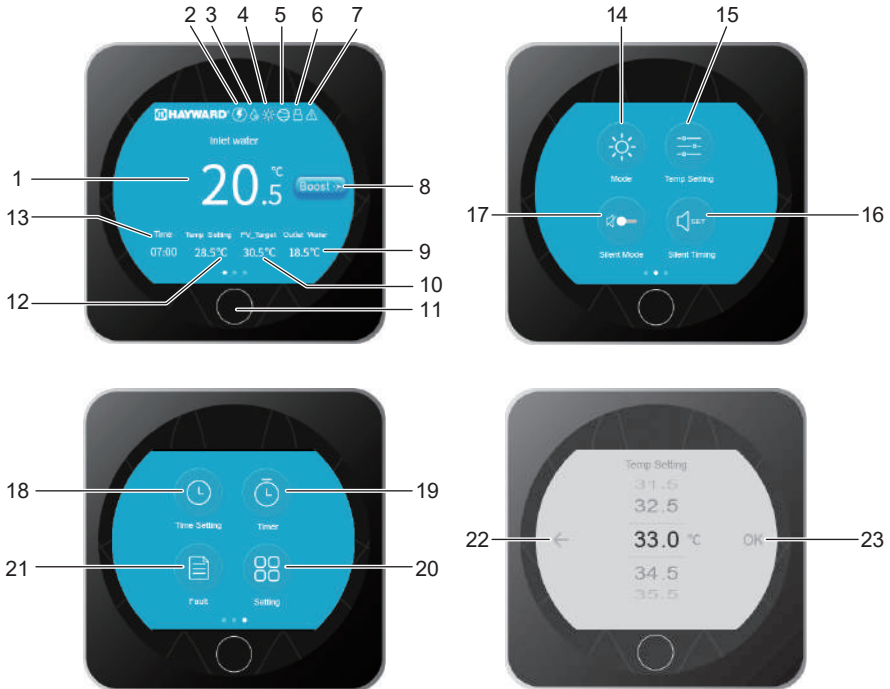

### Legend

1	Water Input temperature
2	PV mode(Sleep/Eco/Power Save/Temp+/Normal)
3	Defrost mode
4	Operating mode
5	Compressor's ON indicator
6	Lock screen
7	Alarm
8	Boost
9	Water Output temperature
10	PV mode setpoint temperature
11	On/Off/Back
12	Setpoint temperature

13	System time
14	Operating mode selection
15	Adjust setpoint
16	Setting silence mode timer
17	Activate silent mode
18	Set date and time
19	Set On/Off timers
20	Access Advanced Settings
21	Access list of faults
22	Back (changes not confirmed)
23	Confirm

## 4. Controlling and Operation

---

### OFF mode

When the heat pump is idle (in standby mode), OFF is displayed as shown on the screen.

The black screen indicates that the heat pump is idle; settings can be adjusted in this mode.



### ON mode

When the heat pump is running or priming (setpoint reached), the screen turns blue.



To switch from OFF to ON mode and vice versa, press the  button for 0.5s.

# 4. Controlling and Operation

## 4.2 Timer function settings

The date and time can be set either in ON or in OFF mode.



- Press 1 times on  to return to the main screen.

# 4. Controlling and Operation

## 4.3 Setting the On/Off timers

The timing switch function means that the heat pump can be turned on at a certain time period and turned off at a certain time period. Therefore, customers can set the on-time and off-time of the heat pump to adjust the timing switch function of the heat pump.

It is possible to set one Start Timer and one Stop Timer. The setting time is "hour to hour".



# 4. Controlling and Operation

---



Blue highlighting = Activated  
Grey = Deactivated

- Press 2 times on  to return to the main screen.

# 4. Controlling and Operation

## 4.4 PV Ready function

The PV Ready icon is displayed on the setting interface. Click to enter the PV control interface. Wiring diagram, description of mode and parameter setting interface can be selected.

If the PV Ready function is not available, the PV Ready icon is not visible.



 Blue highlighting = Activated  
Grey = Deactivated

# 4. Controlling and Operation

## 4.4.1 Single Contact PV control (EM02=1)



- Press 2 times on  to return to the main screen.

# 4. Controlling and Operation

## 4.4.2 Dual Contact PV control (EM02=2)

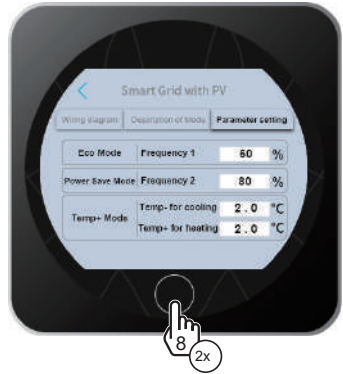
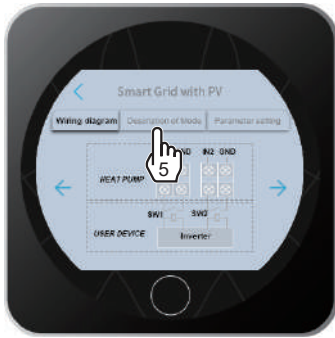

- Press 2 times on  to return to the main screen.

When single/dual contact is selected and PV function is enabled, the PV\_Target temperature is displayed in the main interface, otherwise it is not displayed.

# 4. Controlling and Operation

## 4.5 Spot time

Spot time control function means that the heat pump in a certain period of time to set different target temperature. Therefore, customers can set the parameters to adjust the spot time temperature control function of the heat pump.

A total of 6 timer switch time periods can be set, which can be selected by turning the page.



 Blue highlighting = Activated  
Grey = Deactivated

 The PV ready and Spot time can't be turned on at the same time.

# 4. Controlling and Operation

## 4.6 Adjust setpoint

The setpoint can be changed either in ON or in OFF mode with an accuracy of 0.5°C.



- Press 1 times on  to return to the main screen.

## 4. Controlling and Operation

### 4.7 Locking and unlocking the touch screen

The screen can be locked or unlocked either in ON or in OFF mode.



Lock activated



Lock deactivated

# 4. Controlling and Operation

## 4.8 Silent function settings

Silent mode means that the heat pump is in economic and silent mode. When the energy demand is low, only maintain the temperature of the swimming pool or for the silence of the unit

This function can be Activated/Deactivated manually or using a Timer.

### Activation/Deactivation



- Press 1 times on  to return to the main screen.

# 4. Controlling and Operation

## Adjusting the Silent mode Timer



# 4. Controlling and Operation

---

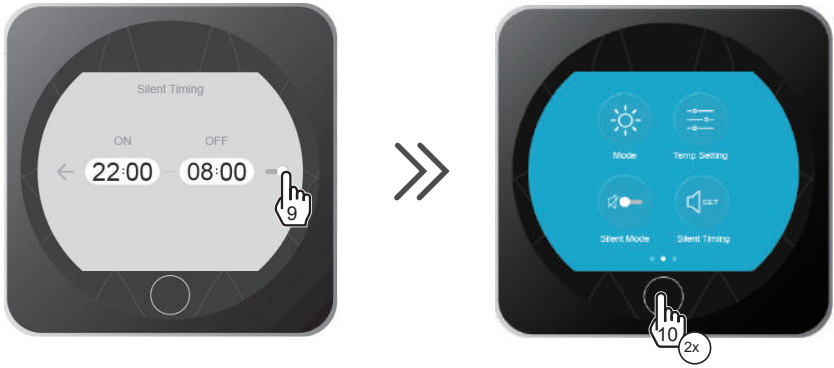

- Press 2 times on  to return to the main screen.

 The setting step is "hour to hour".  
Once the Timer is activated, it is active 7 days a week.

# 4. Controlling and Operation

## 4.9 Troubleshooting guide



 Certain operations must be carried out by an authorized technician.

If a fault occurs on the heat pump  appears in the top left-hand corner of the screen.

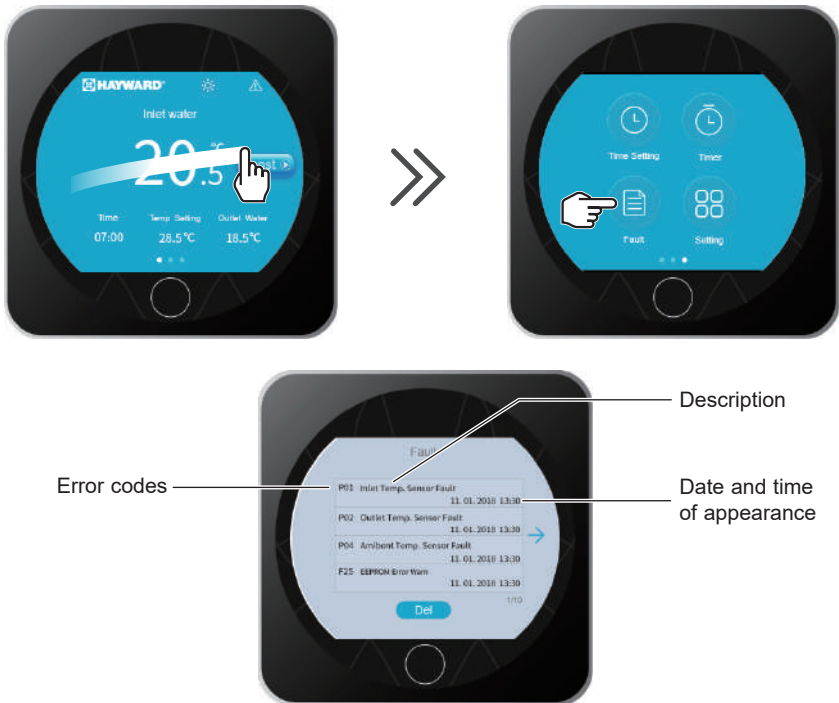
Refer to following table.



 When the problem is resolved, the error is automatically acknowledged and the triangle disappears.

- To delete the error list, press on  .
- Press 2 times on  to return to the main screen.

# 4. Controlling and Operation

## 4.10 Parameter list and breakdown table

### 4.10.1 Electronic control fault table

Can be judged according to the remote controller failure code and troubleshooting.

Protect/fault	Fault display	Reason	Elimination methods
Inlet Temp. Sensor Fault	P01	The temp. sensor is broken or short circuit	Check or change the temp. sensor
Outlet Temp. Sensor Fault	P02	The temp. sensor is broken or short circuit	Check or change the temp. sensor
Ambient Temp. Sensor Fault	P04	The temp. sensor is broken or short circuit	Check or change the temp. sensor
Coil 1 Temp. Sensor Fault	P05	The temp. sensor is broken or short circuit	Check or change the temp. sensor
Coil 2 Temp. Sensor Fault	P15	The temp. sensor is broken or short circuit	Check or change the temp. sensor
Suction Temp. Sensor Fault	P07	The temp. sensor is broken or short circuit	Check or change the temp. sensor
Discharge Temp. Sensor Fault	P081	The temp. sensor is broken or short circuit	Check or change the temp. sensor
Exhaust Air over Temp Prot.	P082	The compressor is overload	Check whether the system of the compressor running normally
Antifreeze Temp. Sensor Fault	P09	Antifreeze temp. sensor is broken or short circuit	Check or change the temp. sensor
Pressure Sensor Fault	PP	The pressure sensor is broken	Check or change the pressure sensor or pressure
High Pressure Prot.	E01	The high-pressure switch is broken	Check the pressure switch and cold circuit
Low Pressure Prot.	E02	The low-pressure switch is broken	Check the pressure switch and cold circuit
Flow Switch Prot.	E03	No water/little water in water system	Check the pipe water flow and water pump
Waterway Anti-freezing Prot.	E05	Water temp. or ambient is too low	Check the water temp. and ambient temp.
Inlet and outlet temp. too big	E06	Water flow is not enough and low differential pressure	Check the pipe water flow and whether water systems jammed or not
Anti-freezing Prot.	E07	Water flow is not enough	Check the pipe water flow and whether water system is jammed or not
Primary Anti-freezing Prot.	E19	The ambient temp. is low	Check the ambient temp. sensor
Secondary Anti-freezing Prot.	E29	The ambient temp. is low	Check the ambient temp. sensor
Comp. Overcurrent Prot.	E051	The compressor is overload	Check whether the system of the compressor running normally
Communication Fault	E08	Communication failure between wire controller and mainboard	Check the wire connection between remote wire controller and main board
Communication Fault (speed control module)	E081	Speed control module and main board communication fail	Check the communication connection
Low AT Protection	TP	Ambient temp. is too low	Check the ambient temp. sensor
EC fan feedback Fault	F051	There is something wrong with fan motor and fan motor stops running	Check whether fan motor is broken or locked or not
Fan Motor1 Fault	F031	1. Motor is in locked-rotor state 2. The wire connection between DC-fan motor module and fan motor is in bad contact	1. Change a new fan motor 2. Check the wire connection and make sure they are in good contact

## 4. Controlling and Operation

Fan Motor2 Fault	F032	1. Motor is in locked-rotor state 2.The wire connection between DC-fan motor module and fan motor is in bad contact	1.Change a new fan motor 2.Check the wire connection and make sure they are in good contact
------------------	------	--	--

### Frequency conversion board fault table:

Protection/fault	Fault display	Reason	Elimination methods
Drv1 MOP alarm	F01	MOP drive alarm	Recovery after the 150s
Inverter offline	F02	Frequency conversion board and mainboard communication failure	Check the communication connection
IPM protection	F03	IPM modular protection	Recovery after the 150s
Comp. Driver Failure	F04	Lack of phase, step or drive hardware damage	Check the measuring voltage , check frequency conversion board hardware
DC Fan Fault	F05	Motor current feedback open circuit or short circuit	Check whether current return wires connected motor
IPM Overcurrent	F06	IPM Input current is large	Check and adjust the current measurement
Inv. DC Overvoltage	F07	DC bus voltage>Dc bus over-voltage protection value	Check the input voltage measurement
Inv. DC Lessvoltage	F08	DC bus voltage<Dc bus over-voltage protection value	Check the input voltage measurement
Inv. Input Lessvolt.	F09	The input voltage is low,causing the incurrent is high	Check the input voltage measurement
Inv. Input Overvolt.	F10	The input voltage is too high,more than outage protection current RMS	Check the input voltage measurement
Inv. Sampling Volt.	F11	The input voltage sampling fault	Check and adjust the current measurement
Comm. Err DSP-PFC	F12	DSP and PFC connect fault	Check the communication connection
Input Over Cur.	F26	The equipment load is too large	Check whether the unit is overloaded
PFC fault	F27	The PFC circuit protection	Check the PFC switch tube short circuit or not
IPM Overheating	F15	The IPM module is overheat	Check and adjust the current measurement
Weak Magnetic Warn	F16	Compressor magnetic force is not enough	Restart the unit after multiple power failures, if the fault still exists, replace the compressor
Inv. Input Out Phase	F17	The input voltage lost phase	Check and measure the voltage adjustment
IPM Sampling Cur.	F18	IPM sampling electricity is fault	Check and adjust the current measurement
Inv. Temp. Probe Fail	F19	The temp. sensor is broken or short circuit	Check or change the temp. sensor
Inverter Overheating	F20	The transducer is overheat	Check and adjust the current measurement
Inv. Overheating Warn	F22	Transducer temperature is too high	Check and adjust the current measurement
Comp. Over Cur. Warn	F23	Compressor electricity is large	The compressor over-current protection
Input Over Cur. Warn	F24	Input current is too large	Check and adjust the current measurement
EEPROM Error Warn	F25	MCU error	Check whether the chip is damaged,replace the chip
V15V over/undervoltage fault	F28	The V15V is overload or undervoltage	Check the V15V input voltage in range 13.5v~16.5v or not

## 4. Controlling and Operation

---

### 4.10.2 Parameter list

Meaning	Default	Remarks
Refrigeration target temperature set point	27 C	Adjustable
Heating the target temperature set point	27 C	Adjustable
Automatic target temperature set point	27 C	Adjustable

### 4.11 Interface drawing

#### 4.11.1 Wire control interface diagram and definition

	Sign	Meaning
	V	12V(power+)
	A	485A
	B	485B
	G	GND (power-)

# 4. Controlling and Operation

## 4.11.2 Controller interface diagram and definition

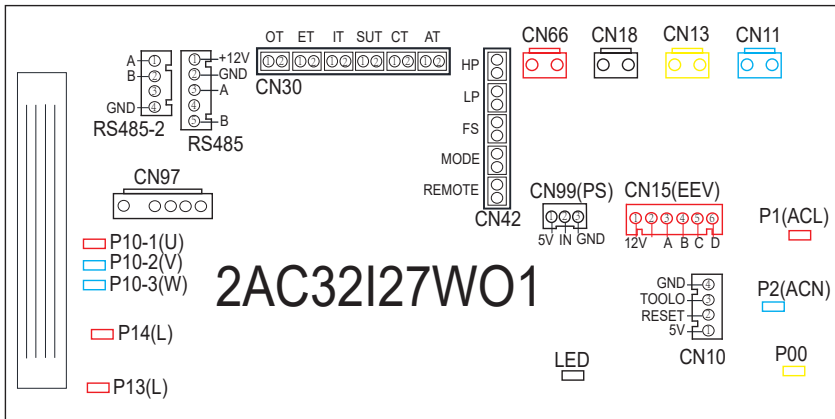
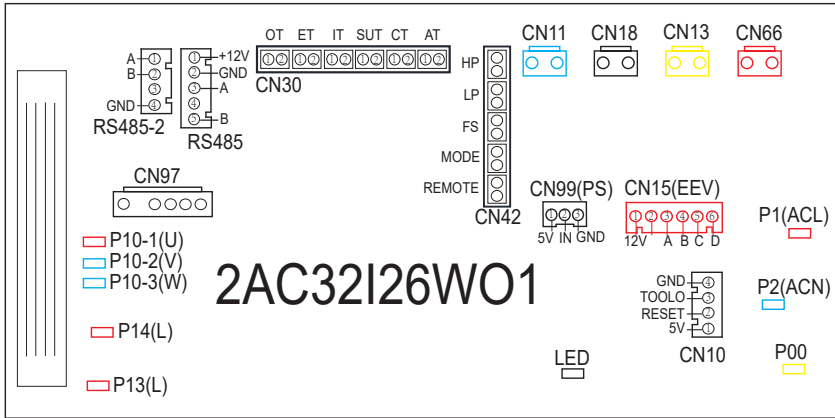

## 4. Controlling and Operation

---

Main board of the input and output interface instructions below

Number	Sign	Meaning
01	P10-1/2/3(U/V/W)	Compressor
02	P13(L)	Resistance
03	P14(L)	Resistance
04	CN97	DC motor
05	RS485-2	The port for centralized control
06	RS485	Color line controller communication
07	OT	Water output temperature
08	ET	System exhaust temperature
09	IT	Water input temperature
10	SUT	System suction temperature
11	CT	System fan coil temperature
12	AT	Ambient temperature
13	HP	System high pressure
14	LP	System low pressure
15	FS	Water flow switch
16	MODE	Mode switch/SW2
17	REMOTE	Emergency switch/SW1
18	CN11	4-way valve
19	CN18	Water pump
20	CN13	Chassis heating belt
21	CN66	Compressor signal
22	CN99	Low pressure sensor
23	CN15	Electronic expansion valve
24	CN10	Program download interface
25	P1	Live wire
26	P2	Neutral wire
27	P00	Grounding

# 4. Controlling and Operation

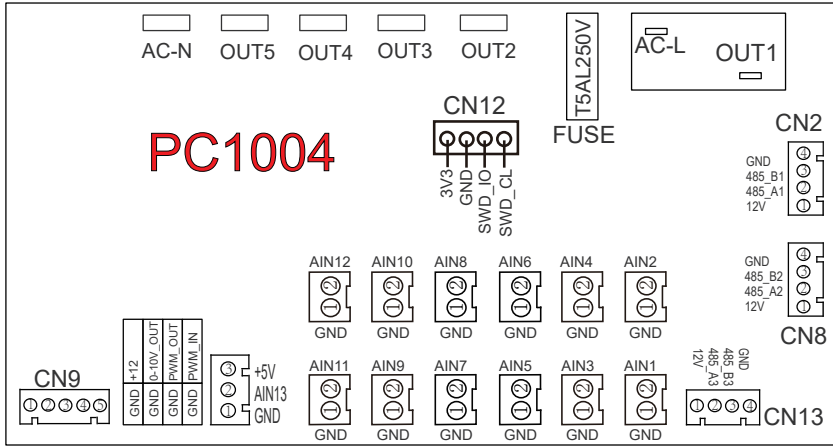

## 4. Controlling and Operation

---

Main board of the input and output interface instructions below

Number	Sign	Meaning
01	OUT1	Compressor
02	OUT2	Water pump
03	OUT3	4-way valve
04	OUT4	High speed of fan
05	OUT5	Low speed of fan/Chassis heating belt
06	L	Live wire
07	N	Neutral wire
08	AIN1	Emergency switch/SW1
09	AIN2	Water flow switch
10	AIN3	System low pressure
11	AIN4	System high pressure
12	AIN5	System suction temperature
13	AIN6	Water input temperature
14	AIN7	Water output temperature
15	AIN8	Coil 1 temperature
16	AIN9	Ambient temperature
17	AIN10	Mode switch/Coil 2 temperature/SW2
18	AIN11	Master-slave machine switch / Antifreeze temperature
19	AIN12	System exhaust temperature
20	AIN13	Compressor current detection/Pressure sensor
21	PWM_IN	Master-slave machine switch / Feedback signal of EC fan
22	PWM_OUT	AC fan control
23	0_10V_OUT	EC fan control
24	+5V	+5V
25	+12V	+12V
26	CN2	Frequency conversion board communications
27	CN8	WIFI / 5 inch color display / DC fan speed regulation module
28	CN9	Electronic expansion valve
29	CN12	Program port
30	CN13	Centralized control communication port

## 5. Use & Operational instructions of WIFI module

---

### *User Privacy Instructions*

---

We take your privacy very seriously and we promise to inform you how we use the data. Users' private data, such as mailboxes, address, before uploading to the cloud, we will get your permission, and we will work hard to protect your data security.

### *Description*

---

- Receive data signal from cloud server and transmit to the main device;
- Receive data signal from main device and transmit to cloud server;
- To achieve remote upgrade the WIFI module baseplate MCU by cloud server;
- To achieve the remote upgrade of the main device by WIFI module baseplate MCU.

### *Technical Parameters*

---

**OPERATING VOLTAGE:** DC8V~12V (Recommended value 12V)

**OPERATING CURRENT:** Max. recurrent peak 1A, average standby current 50mA

**TEMP. RANGE:** Operating Temp.: -30℃~+70℃; Storage Temp.: -40℃~+85℃

**LED INDICATOR LIGHT:**

4 lights, Network configuration indicator, router connection indicator, cloud server connection indicator, 485 communication indicator;

**DIMENSION(L×W×H):** 78mm×63mm×24mm

### *Installation*

---

- There is a magnet on the back of the WIFI module, it can be installed indoors or outdoors, and avoid direct sunlight;
- Please scan the following QR code to download APP;
- Searching the name of the App to be downloaded.



# 5. Use & Operational instructions of WIFI module (Continued)

## Functional Description

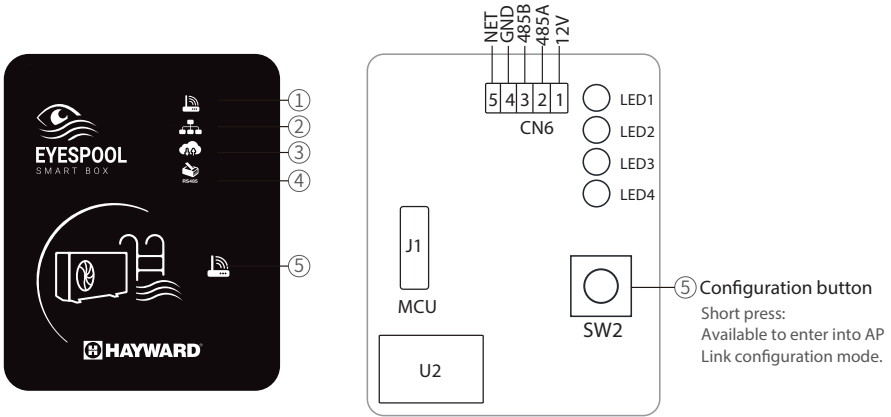

MXL-WX17

ITEM	NAME	LONG LIGHT	SLOW FLASH	EXTINGUISH
①	Network configuration indicator	Configuring Network	SmartLink configuring	Done
②	Router connection indicator	Normal	Abnormal	---
③	Cloud server connection indicator	Normal	Abnormal	---
④	485 communication indicator	Normal	Abnormal	---

## Account Login

Use email address and password to register, login or reset the password.

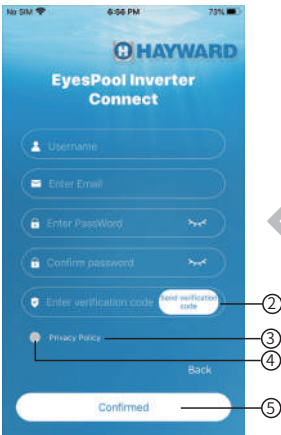

Fig.2 Account Registration interface

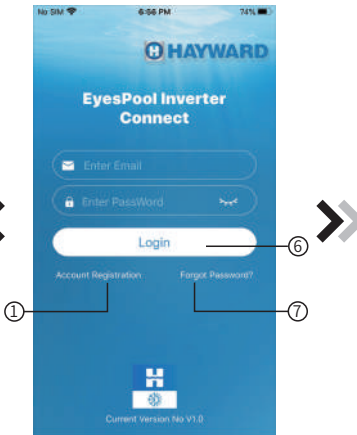

Fig.1 Login interface

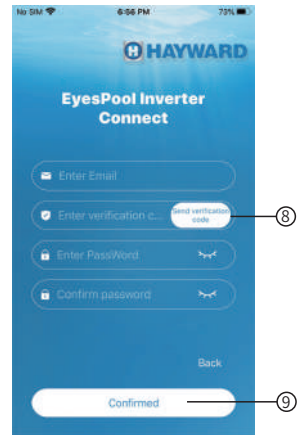

Fig.3 Forgot Password interface

## 5. Use & Operational instructions of WIFI module (Continued)

1. Account Registration: To register an account, click ① (Fig.1) to jump to the Account Registration interface, fill in the relevant information and click ② to receive verification code, while completed the application information, click ③ to read the details of the Privacy Policy, then click ④ to agree, and click ⑤, registration is done.

Please note, the valid time of one verification code is 15min, please fill in the verification code within 15min, otherwise you need to ask for a new one.

2. Log in: Follow the instructions on the page (Fig.1), enter your registered email address and password, click ⑥ and jump to device list;

3. Forgot Password: While forget your password, click ⑦ (Fig.1), jump to the Forgot Password interface (Fig.3). Follow the instructions on the page, fill in the relevant informations, click ⑧ to receive verification code from your mailbox, click ⑨ to confirm and password reset is done.

### Add Device

After log in, displays My Device interface (Fig. 4), follow the instruction to add Bluetooth.

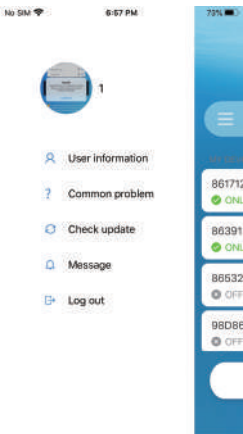

Fig.5 The left-hand menu

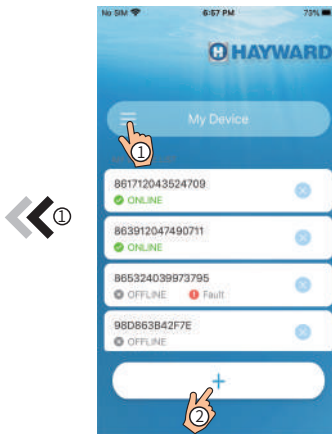

Fig.4 My Device interface

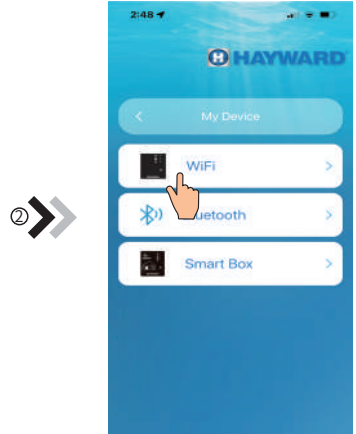

Fig.6 Add Device interface

# 5. Use & Operational instructions of WIFI module (Continued)

## WIFI Configure Network



Fig.7 Permission confirmed interface



Fig.8 WIFI Module On interface

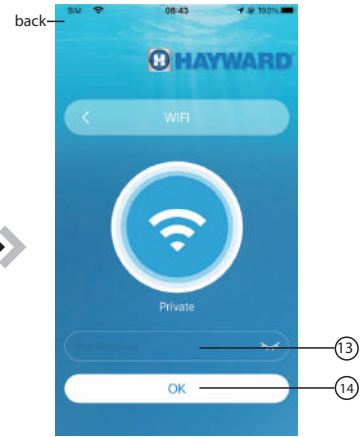

Fig.9 Enter password interface

1. Clic ⑩ to confirm the permission of bluetooth,location and camera(Fig.7);
2. Follow the instructions on the page (Fig.8), press button on module and hold for 1s till two lights o then AP connection is activated, click ⑫ to next;
3. Clic ⑬ to enter the WIFI password for the current connection, click ⑭ to confirm.

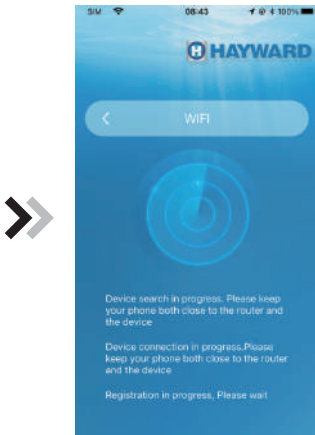

Fig.10 Allow bluetooth permission

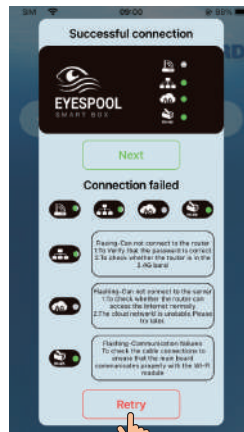

Fig.11 Enable bluetooth permission

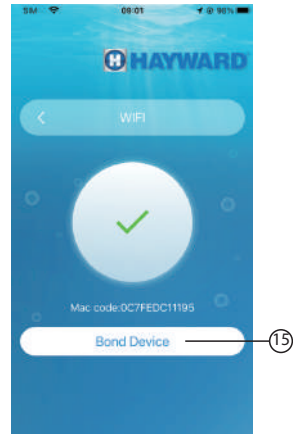

Fig.12 Bluetooth setting interface

# 5. Use & Operational instructions of WIFI module (Continued)

## WIFI Configure Network

4. Turn on bluetooth and back to the APP, directly enter the searching device interface(Fig. 13), If t connection fails or succeeds, a pop-up window will appear. If the connection fails(Fig.11), try again as prompted. If successful(Fig.12), check the light 1 of the wifi module indicator, and then select the operation according to the prompts.
5. Click (15) to bond device (Fig.12);
6. Click "Allow" (Fig.17) to allow the App to use the camera for scanning the WF code on the WIFI module (Fig.15), or click "manual input" to enter the WF code. Check the WF code being scanned in to IOT code
7. Click "Comfirm", device bond is done (Fig.16)
8. Check the wifi module indicators should be lit as Fig.17 after successful configuratio

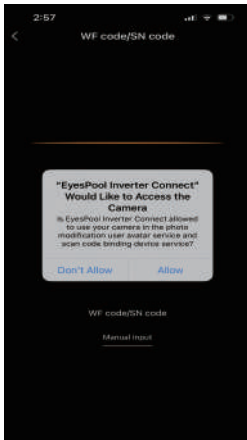

Fig.13 Enable camera permission

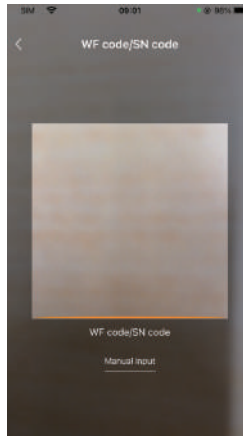

Fig.14 Scanning interface



Fig.15 WF barcode



Fig.16 Bond device done interface



Fig.17 Wifi module indicators after successful

# 5. Use & Operational instructions of WIFI module (Continued)

## Device Management

Device management operations are as below :

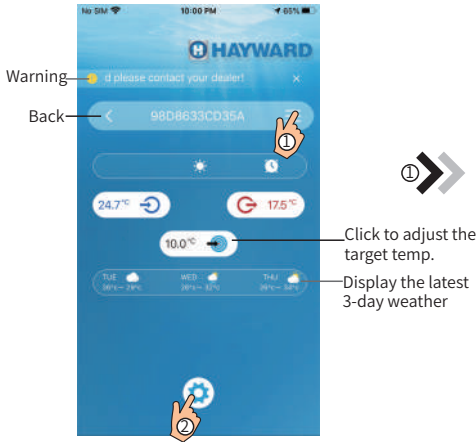

Fig.18 Device Main interface

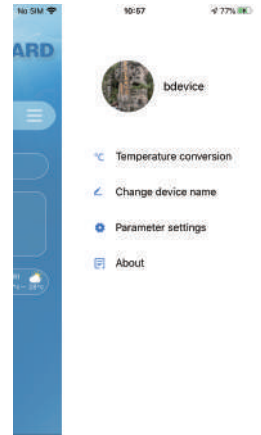

Fig.19 The right-hand menu interface



Fig.21 Timing Settings interface



Fig.20 Device Main interface

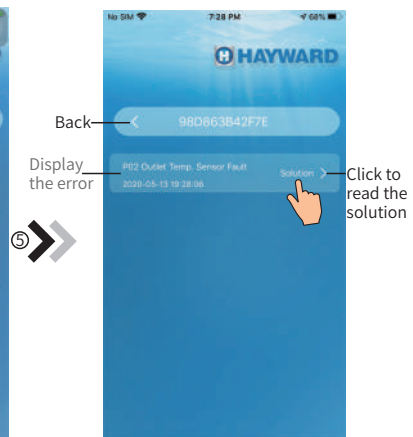









Fig. 22 Troubleshooting interface

## 5. Use & Operational instructions of WIFI module (Continued)

ICON	NAME	FUNCTIONS
	ON/ OFF	Click it to turn on/ off the unit
	Mode shift	Mode changing: Cooling--Heating--Auto
	Cooling	Display Cooling mode, click it to change operating mode
	Heating	Display Heating mode, click it to change operating mode
	Auto	Display Auto mode, click it to change operating mode
	Timming settings	Click it to jump to the timer on/ off and mute timer setting interface
	Troubleshooting	Click it to jump to the troubleshooting interface
	Menu	Click to unfold or collapse the menu
	Refresh	Retrieve the server data and update the APP display

## 6. MAINTENANCE AND INSPECTION

---

- Check the water supply device and the release often. You should avoid the condition of no water or air entering into system, as this will influence unit's performance and reliability. Regularly maintaining the pool/spa filter is essential to prevent any harm to the unit caused by a filthy or obstructed filter.  
The area around the unit should be dry, clean and well ventilated. Clean the side heating exchanger regularly to maintain good heat transfer to conserve energy .
- The operational pressure of the refrigerant system should only be checked by a certified technician .
- Regularly inspect the power supply and cable connections. If the appliance starts to function in an unexpected manner, turn it off and get in touch with a skilled expert.
- Checks to the area  
Before commencing work on systems that contain flammable refrigerants, it is essential to conduct safety tests in order to limit the danger of ignition. Prior to undertaking work on the refrigerating system, it is necessary to comply with the following measures for repair.
- Work procedure  
Work shall be undertaken under a controlled procedure to minimise the risk of a flammable gas or vapor being present while the work being performed.
- General work area  
All maintenance staff and others working in the local area shall be instructed on the nature of work being carried out. Work in confined spaces shall be avoided. The area around the workspace shall be sectioned off. Ensure that the conditions within the area have been made safe by control of flammable material.
- Checking for presence of refrigerant  
The area shall be checked with an appropriate refrigerant detector prior to and during work, to ensure the technician is aware of potentially flammable atmospheres. Ensure that the leak detection equipment being used is suitable for use with flammable refrigerants, i.e. non-sparking, adequately sealed or intrinsically safe.
- Presence of fire extinguisher  
If any hot work is to be conducted on the refrigeration equipment or any associated parts, appropriate fire extinguishing equipment shall be available to hand. Have a dry powder or CO2 fire extinguisher adjacent to the charging area.

## 6. MAINTENANCE AND INSPECTION

---

### ● Ignition sources

Individuals working on a refrigeration system involving exposed pipes containing or previously contained flammable refrigerant must not utilise any sources of ignition in a way that could potentially cause a fire or explosion. It is important to keep all potential ignition sources, such as cigarette smoking, at a safe distance from the area where installation, repair, removal, and disposal activities are taking place. This is particularly important when there is a possibility of releasing flammable refrigerant into the surrounding space. Before commencing work, it is necessary to inspect surrounding region to ensure that there are no potential sources of flammable dangers or fire threats. It is required to show signs that prohibit smoking.

### ● Ventilated area

Prior engaging in any hot work relate to refrigerant circuit, it is imperative to confirm that the space is either exposed to the open air or possesses sufficient ventilation. Continuous ventilation is required throughout the duration of the work. The ventilation system should effectively disperse any refrigerant that is released and ideally expel it outside into the atmosphere.

### ● Equipment checks

Electrical components that are being replaced must be suitable for the intended use and meet the appropriate specifications. The manufacturer's maintenance and service requirements must always be adhered.

The following checks shall be applied to installations using flammable refrigerants:

If ventilation system in use, make sure the vents are operating adequately and are not obstructed;

If an indirect refrigerating circuit is being used, the secondary circuit shall be checked for the presence of refrigerant;

The refrigeration pipe or components are placed in a location where they are not likely to come into contact with any substances that could corrode the refrigerant-containing components, unless the components are made of materials that are naturally resistant to corrosion or are adequately protected against corrosion.

### ● Electrical checks

Repair and maintenance to electrical components shall include initial safety checks and component inspection procedures. The appliance should not be use in any means If a fault exists that could compromise the safety,

Under no circumstances can circuit boards be touched with bare hands during or immediately after the operation.

Ensure that no live wires are exposed while charging, recovering, or purging the system.

Make sure that the heat pump is properly grounded to the earth.

## 6. MAINTENANCE AND INSPECTION

---

### ● Repairs to sealed components

1) Before removing sealed covers or any other components, all electrical supply must be disconnected from the equipment being repaired. If there is an absolute need for an electrical supply to equipment during service, a continuously functioning leak detection system must be installed at the most relevant location to alert of any potentially dangerous condition.

2) Special emphasis must be placed on the following to guarantee that when working on electrical components, the casing is not modified in a manner that compromises the level of protection. This encompasses several factors such as cable damage, an excessive number of connections, terminals that do not meet the original specifications, seal damage, and inappropriate installation of glands.

### ● Ensure that appliance is mounted securely.

Ensure the seals or sealing materials have not degraded such that they no longer serve the purpose of preventing the ingress of flammable atmospheres. Replacement parts shall be in accordance with the manufacturer's specifications.

NOTE: The use of silicon sealant may inhibit the effectiveness of some types of leak detection equipment. Intrinsically safe components do not have to be isolated prior to working on them.

### ● Repairs to intrinsically safe components

Do not apply any permanent inductive or capacitance loads to the circuit without ensuring that this will not exceed the permissible voltage and current permitted for the equipment in use.

Intrinsically safe components are the only types that can be worked on while live in the presence of a flammable atmosphere. The test apparatus shall be at the correct rating. Replace components only with parts specified by the manufacturer. Other parts may result in the ignition of refrigerant in the atmosphere from a leak.

### ● Cabling

Ensure that the cabling is not susceptible to wear, corrosion, extreme pressure, vibration, sharp edges, or any other detrimental environmental factors. The assessment will also consider the impact of ageing or persistent vibration caused by sources such as compressors or fans.

### ● Detection of flammable refrigerants

Under no circumstances shall potential sources of ignition be used in the searching for or detection of refrigerant leaks. A halide torch (or any other detector using a naked flame) shall not be used.

### ● Leak detection methods

The following leak detection methods are deemed acceptable for systems containing flammable refrigerants.

Electronic leak detectors shall be used to detect flammable refrigerants, but the sensitivity may not be adequate, or may need re-calibration. (Detection equipment shall be calibrated in a refrigerant-free area.) Ensure that the detector is not a potential source of ignition and is suitable for the refrigerant used. Leak detection equipment shall be set at a percentage of the LFL of the refrigerant and shall be calibrated to the refrigerant employed and the appropriate percentage of gas (25 % maximum) is confirmed.

Leak detection fluids are suitable for use with most refrigerants but the use of detergents containing chlorine shall be avoided as the chlorine may react with the refrigerant and corrode the copper pipe-work.

If a leak is suspected, all naked flames shall be removed/ extinguished.

If a leakage of refrigerant is found which requires brazing, all of the refrigerant shall be recovered from the system, or isolated (by means of shut off valves) in a part of the system remote from the leak. Oxygen free nitrogen (OFN) shall then be purged through the system both before and during the brazing process.

## 6. MAINTENANCE AND INSPECTION

---

### ● Removal and evacuation

When breaking into the refrigerant circuit to make repairs or for any other purpose conventional procedures shall be used. However, it is important that best practice is followed since flammability is a consideration. The following procedure shall be adhered to: . Remove refrigerant;

- . Purge the circuit with inert gas;
- . Evacuate;
- . Purge again with inert gas;
- . Open the circuit by cutting or brazing.

The refrigerant charge shall be recovered into the correct recovery cylinders. The system shall be "flushed" with OFN to render the unit safe. This process may need to be repeated several times. Compressed air or oxygen shall not be used for this task.

Flushing shall be achieved by breaking the vacuum in the system with OFN and continuing to fill until the working pressure is achieved, then venting to atmosphere, and finally pulling down to a vacuum. This process shall be repeated until no refrigerant is within the system. When the final OFN charge is used, the system shall be vented down to atmospheric pressure to enable work to take place. This operation is absolutely vital if brazing operations on the pipe-work are to take place. Ensure that the outlet for the vacuum pump is not close to any ignition sources and there is ventilation available. working on them.

### ● Labelling

The equipment must be clearly marked to indicate that it has been decommissioned and all refrigerant has been removed. The label must be both dated and signed. Make sure that the equipment is clearly labeled to indicate that it contains a refrigerant that is flammable.

### ● Recovery

When extracting refrigerant from a system, whether for maintenance or decommissioning purposes, it is advisable to follow proper protocols to ensure the safe removal of all refrigerants..

When transferring refrigerant into cylinders, make sure to use only suitable refrigerant recovery cylinders. Verify the presence of the appropriate number of cylinders capable of containing the entire system charge. All cylinders intended for usage must be specifically labelled and labelled for the recovered refrigerant, ensuring they are suitable for the purpose of refrigerant recovery. The cylinders must be equipped with a pressure relief valve and functioning shut-off valves. Before recovery takes place, it is necessary to remove and, if feasible, cool the empty recovery cylinders.

The recovery equipment must be in optimal operational condition, accompanied by a comprehensive set of instructions specific to the equipment, and capable of effectively recovering flammable refrigerants. Furthermore, there must be a set of accurately calibrated weighing scales that are readily accessible and in optimal operational condition. The hoses must be equipped with disconnect couplings that are free from leaks and must be in a satisfactory condition. Prior to utilising the recovery machine, ensure that it is in a suitable operational state, has undergone appropriate maintenance, and that any related electrical elements are securely sealed to prevent ignition in case of a refrigerant discharge. Seek guidance from the manufacturer if you are uncertain.

The recovered refrigerant shall be returned to the refrigerant supplier in the correct recovery cylinder, and the relevant Waste Transfer Note arranged. Do not mix refrigerants in recovery units and especially not in cylinders.

If compressors or compressor oils are to be removed, ensure that they have been evacuated to an acceptable level to make certain that flammable refrigerant does not remain within the lubricant. The evacuation process shall be carried out prior to returning the compressor to the suppliers. Only electric heating to the compressor body shall be employed to accelerate this process. When oil is drained from a system, it shall be carried out safely.

## 6. MAINTENANCE AND INSPECTION

---

### ● **Decommissioning**

Before carrying out this procedure, it is essential that the technician is completely familiar with the equipment and all its detail. It is recommended good practice that all refrigerants are recovered safely. Prior to the task being carried out, an oil and refrigerant sample shall be taken in case analysis is required prior to re-use of reclaimed refrigerant. It is essential that electrical power is available before the task is commenced.

- a) Become familiar with the equipment and its operation.
- b) Isolate system electrically.
- c) Before attempting the procedure ensure that:
  - . Mechanical handling equipment is available, if required, for handling refrigerant cylinders;
  - . All personal protective equipment is available and being used correctly;
  - . The recovery process is supervised at all times by a competent person;
  - . Recovery equipment and cylinders conform to the appropriate standards.
- d) Pump down refrigerant system, if possible.
- e) If a vacuum is not possible, make a manifold so that refrigerant can be removed from various parts of the system.
- f) Make sure that cylinder is situated on the scales before recovery takes place.
- g) Start the recovery machine and operate in accordance with manufacturer's instructions.
- h) Do not overfill cylinders. (No more than 80 % volume liquid charge).
- i) Do not exceed the maximum working pressure of the cylinder, even temporarily.
- j) When the cylinders have been filled correctly and the process completed, make sure that the cylinders and the equipment are removed from site promptly and all isolation valves on the equipment are closed off.
- k) Recovered refrigerant shall not be charged into another refrigeration system unless it has been cleaned and checked.

### ● **Charging procedures**

In addition to conventional charging procedures, the following requirements shall be followed.

- Ensure that contamination of different refrigerants does not occur when using charging equipment. Hoses or lines shall be as short as possible to minimise the amount of refrigerant contained in them.
- Cylinders shall be kept upright.
- Ensure that the refrigeration system is earthed prior to charging the system with refrigerant.
- Label the system when charging is complete (if not already).
- Extreme care shall be taken not to overfill the refrigeration system.

Prior to recharging the system it shall be pressure tested with OFN. The system shall be leak tested on completion of charging but prior to commissioning. A follow up leak test shall be carried out prior to leaving the site.

- The safety wire model is 5\*20\_5A/250VAC, And must meet the explosion-proof requirements

# 7. APPENDIX

## 7.1 Cable specification

### (1) Single phase unit

Nameplate maximum current	Phase line	Earth line	MCB	Creepage protector	Signal line
No more than 10A	2×1.5mm <sup>2</sup>	1.5mm <sup>2</sup>	20A	30mA less than 0.1 sec	n×0.5mm <sup>2</sup>
10~16A	2×2.5mm <sup>2</sup>	2.5mm <sup>2</sup>	32A	30mA less than 0.1 sec	
16~25A	2×4mm <sup>2</sup>	4mm <sup>2</sup>	40A	30mA less than 0.1 sec	
25~32A	2×6mm <sup>2</sup>	6mm <sup>2</sup>	40A	30mA less than 0.1 sec	
32~40A	2×10mm <sup>2</sup>	10mm <sup>2</sup>	63A	30mA less than 0.1 sec	
40~63A	2×16mm <sup>2</sup>	16mm <sup>2</sup>	80A	30mA less than 0.1 sec	
63~75A	2×25mm <sup>2</sup>	25mm <sup>2</sup>	100A	30mA less than 0.1 sec	
75~101A	2×25mm <sup>2</sup>	25mm <sup>2</sup>	125A	30mA less than 0.1 sec	
101~123A	2×35mm <sup>2</sup>	35mm <sup>2</sup>	160A	30mA less than 0.1 sec	
123~148A	2×50mm <sup>2</sup>	50mm <sup>2</sup>	225A	30mA less than 0.1 sec	
148~186A	2×70mm <sup>2</sup>	70mm <sup>2</sup>	250A	30mA less than 0.1 sec	
186~224A	2×95mm <sup>2</sup>	95mm <sup>2</sup>	280A	30mA less than 0.1 sec	

### (2) Three phase unit

Nameplate maximum current	Phase line	Earth line	MCB	Creepage protector	Signal line
No more than 10A	3×1.5mm <sup>2</sup>	1.5mm <sup>2</sup>	20A	30mA less than 0.1 sec	n×0.5mm <sup>2</sup>
10~16A	3×2.5mm <sup>2</sup>	2.5mm <sup>2</sup>	32A	30mA less than 0.1 sec	
16~25A	3×4mm <sup>2</sup>	4mm <sup>2</sup>	40A	30mA less than 0.1 sec	
25~32A	3×6mm <sup>2</sup>	6mm <sup>2</sup>	40A	30mA less than 0.1 sec	
32~40A	3×10mm <sup>2</sup>	10mm <sup>2</sup>	63A	30mA less than 0.1 sec	
40~63A	3×16mm <sup>2</sup>	16mm <sup>2</sup>	80A	30mA less than 0.1 sec	
63~75A	3×25mm <sup>2</sup>	25mm <sup>2</sup>	100A	30mA less than 0.1 sec	
75~101A	3×25mm <sup>2</sup>	25mm <sup>2</sup>	125A	30mA less than 0.1 sec	
101~123A	3×35mm <sup>2</sup>	35mm <sup>2</sup>	160A	30mA less than 0.1 sec	
123~148A	3×50mm <sup>2</sup>	50mm <sup>2</sup>	225A	30mA less than 0.1 sec	
148~186A	3×70mm <sup>2</sup>	70mm <sup>2</sup>	250A	30mA less than 0.1 sec	
186~224A	3×95mm <sup>2</sup>	95mm <sup>2</sup>	280A	30mA less than 0.1 sec	

When the unit will be installed at outdoor, please use the cable which can against UV.

## 7.APPENDIX

---

### 7.2 Comparison table of refrigerant saturation temperature

Pressure (MPa)	0	0.3	0.5	0.8	1	1.3	1.5	1.8	2	2.3
Temperature (R410A)(°C)	-51.3	-20	-9	4	11	19	24	31	35	39
Temperature (R32)(°C)	-52.5	-20	-9	3.5	10	18	23	29.5	33.3	38.7
Pressure (MPa)	2.5	2.8	3	3.3	3.5	3.8	4	4.5	5	5.5
Temperature (R410A)(°C)	43	47	51	55	57	61	64	70	74	80
Temperature (R32)(°C)	42	46.5	49.5	53.5	56	60	62	67.5	72.5	77.4



# KEEP THIS BOOKLET



Hayward Pool Products (Australia) Pty Ltd. Melbourne-Sydney-Brisbane-Perth  
Email: [sales@hayward-pool.com.au](mailto:sales@hayward-pool.com.au) | Website: [au.hayward.com](http://au.hayward.com)  
PO Box 4384 | Dandenong South VIC 3164  
ABN 66 083 413 414 Sales  
Contact Ph: 1300POOLS1 Fax: 1300POOLS2